

QG series

QG40-KD-090E-AV-CM-UL

Inclination sensor

2-axis

Non-programmable device

Output: 0,5 - 4,5 V

2-axis horizontal mounting
1-axis hori-/vertical mounting

Measuring range
 $\pm 90^\circ$

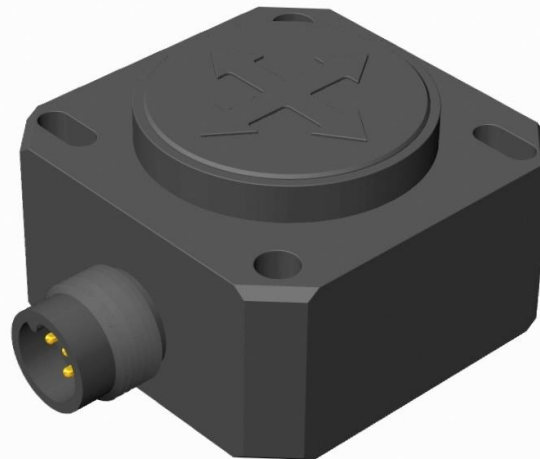

General specifications 12285, v20210611

Housing	Plastic injection molded housing (Arnite T06 202 PBT black)
Dimensions (indicative)	40x40x25 mm
Mounting	Included: 2x M3x25 mm zinc plated steel pozidrive pan head screws, self-tapping (PZ DIN 7500CZ) Mounting on flat surface only. Screw with maximum Torque 2 Nm
Ingress Protection (IEC 60529)	IP67, IP69K (with IP69K mating connector)
Relative humidity	0 - 95% (non condensing, housing fully potted)
Weight	approx. 45 gram
Supply voltage	10 - 30 V dc
Polarity protection	Yes
Current consumption	≤ 10 mA
Operating temperature	-40 .. +80 °C
Storage temperature	-40 .. +85 °C
Measuring range	$\pm 90^\circ$
Centering function	No
Frequency response (-3dB)	0 - 10 Hz ($\pm 2,5$ Hz)
Accuracy (overall @20°C)	0,9° typ. (offset excluded) (-45°...+45°)
Offset error	$\pm 1^\circ$ typ. ($\pm 3^\circ 2\sigma$)
Non linearity	$\pm 0,6^\circ$ typ. (-45°...+45°)
Sensitivity error	$\pm 2\%$ typ., Repeatability 0.1°
Resolution	0,03°
Temperature coefficient	$\pm 0,02^\circ/\text{K}$ typ.
Max mechanical shock	3.500g
Output	0,5 - 4,5 V
Output load	Rload $\geq 20\text{k}\Omega$, Cload ≤ 20 nF
Short circuit protection	Yes (max 10 s)
Output refresh rate	continuous (analog)
Programming options	not applicable

QG40-KD-090E-AV-CM-UL

$$U_{out} = 2,5 + 2 \cdot \sin(\alpha) \text{ [V]}$$

Transfer characteristic

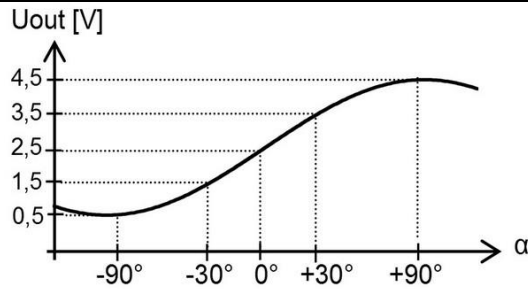

0° positions drawn in plot at the right.

Horizontal mounting:
1-axis or 2-axis usage
Connect output-X and/or output-Y according the plot at the right.

In case of 2-axis usage:
Tilting one axis will influence the other axis, significant influence (10%) when > 25°.

Upside down mounting possible
(sensor-nose down)

Vertical mounting:
1-axis usage only
Connect output-X and/or output-Y according the plot at the right.

Connector down: Y-output not valid
Mounting with M12 to top possible

Connector side: X-output not valid
Mounting with M12 to left possible

Measurement orientation

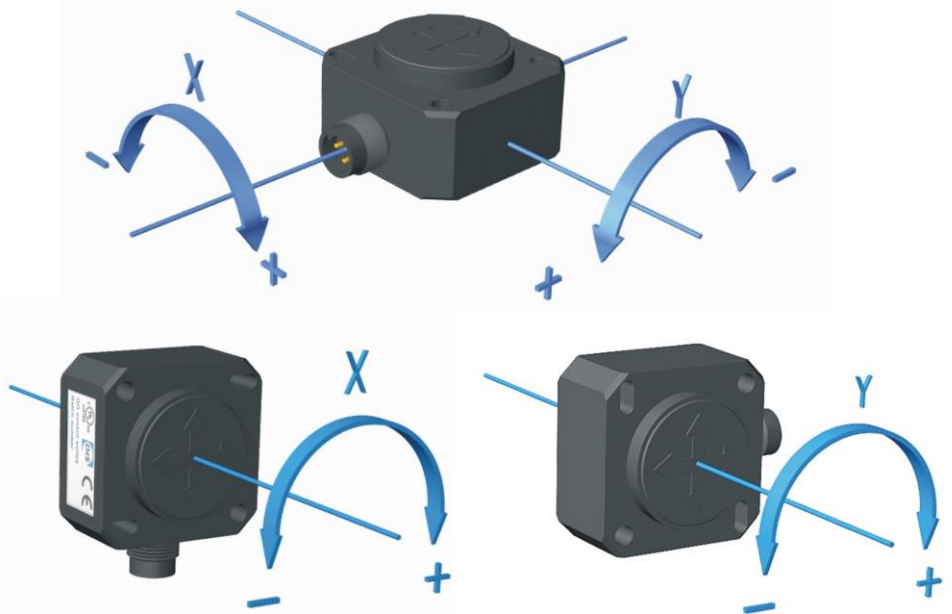

Connectivity (cable length ±10%)

M12 5p male connector (Glass fibre reinforced grade, contacts CuZn pre-nickeled galv. Au)

Pin 1: + Supply Voltage
Pin 2: output Y
Pin 3: Gnd
Pin 4: output X
Pin 5: not connected

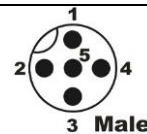

If connected with M12 F (accessory sold by DIS):

Brown: + Supply Voltage
White: output Y
Blue: Gnd
Black: output X
Green/yellow: not connected

Connection

Wire / pin coding

Mechanical dimensions (indicative only)

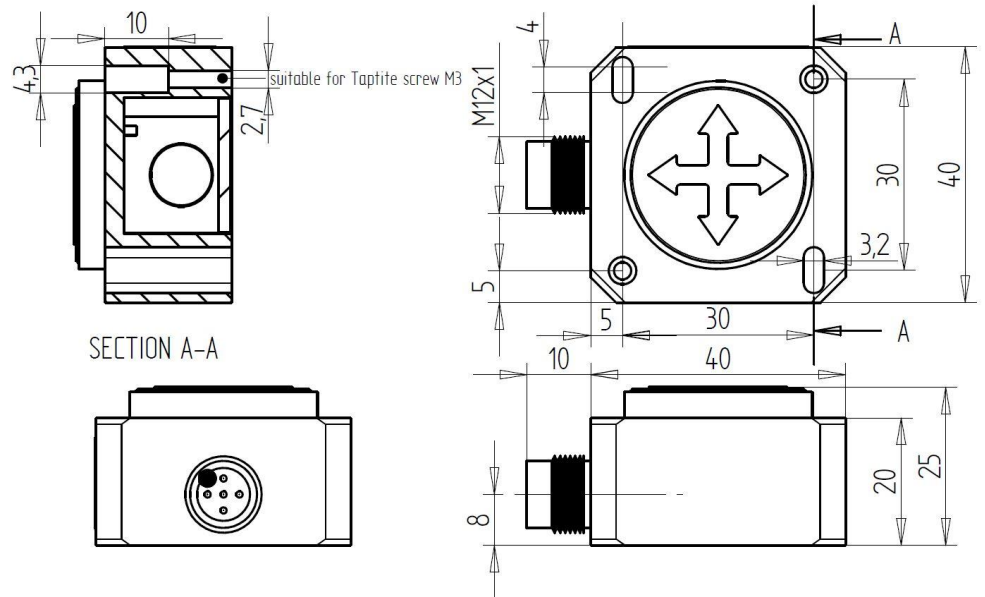

Intended use, UL, Remarks

QG series sensors are intended to measure inclination, acceleration or tilt angle after installing in machines, equipment and systems. Flawless function in accordance with the specifications is ensured only when the device is used within its specifications. This device is not a safety component according to the EU Machine Directive (ISO13849). For full redundancy two devices can be used in the application. Modifications or non-approved use are not permitted and will result in loss of warranty and void any claims against the manufacturer.

UL & c-UL listed product (File number E312057, UL508 standards UL60947-5-2 & CSA-C22.2 No. 14)
 Product Identity / Category Code Number (CCN): Industrial Control Equipment / NRKH & NRKH7
 Enclosure rating: type 1, Ambient temperature: max 80 °C (see also datasheet, lowest value applies)
 Electrical ratings: Intended to be used with a Class 2 power source in accordance with UL1310,
 max. input Voltage 32V dc (see also datasheet, lowest value applies), max. current 200mA
 Accessory Cable Assembly: Any UL-listed (CYJV/7) mating connector with mechanical locking, wire
 thickness of at least 30 AWG (0,05 mm²), recommended ≤23 AWG (≥0,25 mm²)

As this device is accelerometer-based the sensor is inherent sensitive for accelerations/vibrations.
 Application specific testing must be carried out to check whether this sensor will fulfil your requirements.