

QG series

QG40N-series

QG40N-KDXyh-010-AI-CM-UL

Inclination sensor

2 axis horizontal mounting

Programmable device

Output: 4 - 20 mA

Measuring range programmable
between $\pm 1^\circ$ and $\pm 10^\circ$

Measuring range
Factory defaults: $\pm 10^\circ$

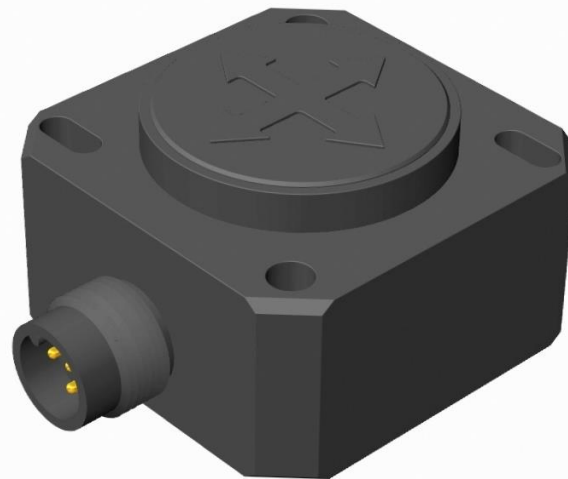

General specifications 11923B, v20241216

Plastic injection molded housing (Arnite T06 202 PBT black)

40x40x25 mm

Included: 2x M3x25 mm zinc plated steel pozidrive pan head screws, self-tapping (PZ DIN 7500CZ)
Mounting on flat surface only. Screw with care

IP67, IP69K (with IP69K mating connector)

0 - 95% (non condensing, housing fully potted)

approx. 45 gram

10 - 30 V dc

Yes

≤ 15 mA (excluding output signal)

-40 .. +80 °C

-40 .. +85 °C

Factory defaults: $\pm 10^\circ$

Yes (12 mA = 0°), range: $\pm 5^\circ$

0 - 10 Hz

0,5° typ.

$\pm 0,2^\circ$ typ. after centering

$\pm 0,4^\circ$ typ.

not applicable. Repeatability $0,2^\circ$

0,1°

$\pm 0,04^\circ/\text{K}$ typ.

10.000g

4 - 20 mA

$22 \text{ Ohm} \leq R_{\text{load}} \leq (50 \cdot V_s - 300) (\Omega)$ (Eg: $V_s = 24 \text{ V}$: $R_{\text{load}} \leq 900 \Omega$)

Yes ($T < 55^\circ\text{C}$), Max 10 s ($T > 55^\circ\text{C}$)

20 ms

by optional QG40N-configurator (measuring range, filtering)

Housing

Dimensions (indicative)

Mounting

Ingress Protection (IEC 60529)

Relative humidity

Weight

Supply voltage

Polarity protection

Current consumption

Operating temperature

Storage temperature

Measuring range

Centering function

Frequency response (-3dB)

Accuracy (overall @20°C)

Offset error

Non linearity

Sensitivity error

Resolution

Temperature coefficient

Max mechanical shock

Output

Output load

Short circuit protection

Output refresh rate

Programming options

QG series

QG40N-KDXYh-010-AI-CM-UL

$I_{out} = 12 + 8(\alpha/10)$ [mA]
 clipping outside measuring range

 Centering: eliminate mech. offsets
 Connect center input to ground
 (>0,5sec) within 1 min. after power up.
 Normally the center input should be left unconnected.

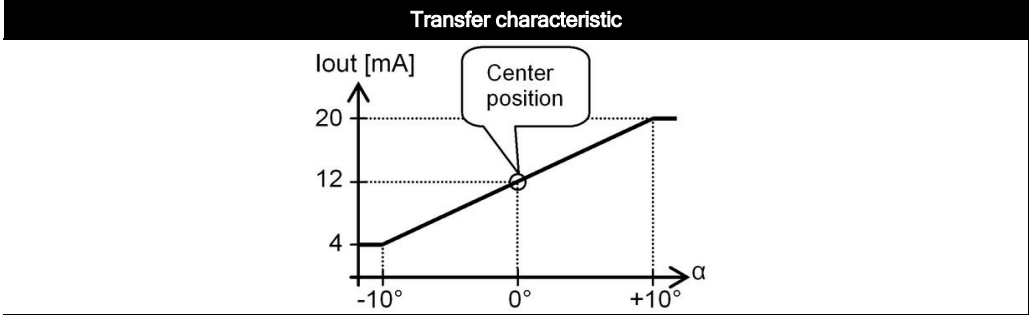

Default 0°: horizontal (round nose upwards), no acceleration applied.

 Cross tilt sensitivity error:
 $< (0,12 * \text{cross tilt angle})^2$ % typ.

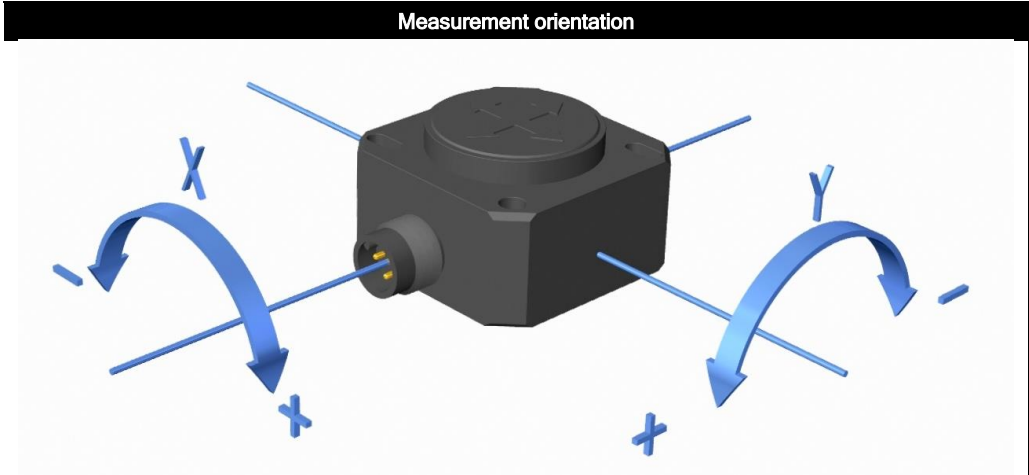

Connection

 Wire / pin coding

Connectivity (cable length ±10%)

M12 5p male connector (Glass fibre reinforced grade, contacts CuZn pre-nickeled galv. Au)

Pin 1:	+ Supply Voltage	<p style="text-align: center;">3 Male</p>
Pin 2:	output Y	
Pin 3:	Gnd	
Pin 4:	output X	
Pin 5:	centering	

If connected with M12 F (accessoire sold by DIS):

Brown:	+ Supply Voltage
White:	output Y
Blue:	Gnd
Black:	output X
Green/yellow:	centering

Mechanical dimensions (indicative only)

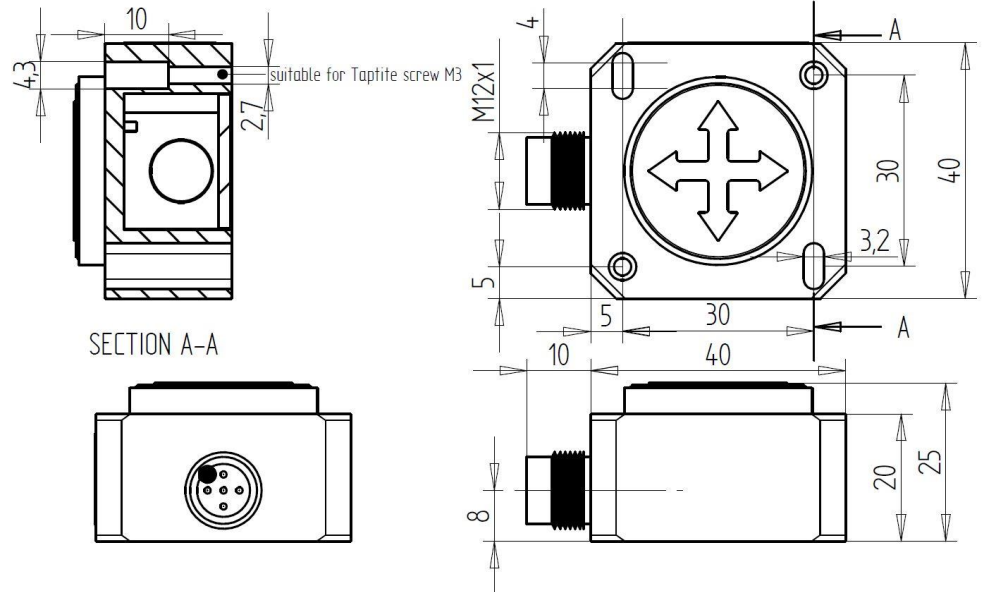

Intended use, UL, Remarks

QG series sensors are intended to measure inclination/acceleration/tilt. Flawless function (acc. spec.) is ensured only when used within specifications. This device is not a safety component acc. to EU Machine Directive (ISO13849). For full redundancy two devices can be used. Modifications or non-approved use will result in loss of warranty and void any claims against the manufacturer.

UL & c-UL listed product (File number E312057, UL508 standards UL60947-5-2 & CSA-C22,2 No. 14)
 Product Identity / Category Code Number (CCN): Industrial Control Equipment / NRKH & NRKH7
 Enclosure rating: type 1, Ambient temperature: max 80 °C (see also datasheet, lowest value applies)
 Electrical ratings: Intended to be used with a Class 2 power source in accordance with UL1310,
 max. input Voltage 32V dc (see also datasheet, lowest value applies), max. current 200mA
 Accessory Cable Assembly: Any UL-listed (CYJV/7) mating connector with mechanical locking, wire
 thickness of at least 30 AWG (0,05 mm²), recommended ≤23 AWG (≥0,25 mm²)

As this device is accelerometer-based the sensor is inherent sensitive for accelerations/vibrations.
 Application specific testing must be carried out to check whether this sensor will fulfil your requirements.