

QG series

QG40N-series

QG40N-KDXYh-080-ASP-CM-UL

Tilt switch

2 axis horizontal mounting

Programmable device

Output: PNP

Switch points programmable
between $\pm 1^\circ$ and $\pm 80^\circ$

Measuring range
Factory defaults: $\pm 80^\circ$

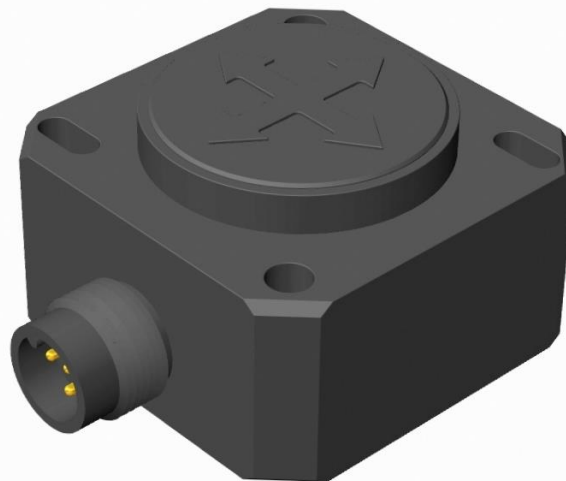

General specifications 11630B, v20241216

Housing	Plastic injection molded housing (Arnite T06 202 PBT black)
Dimensions (indicative)	40x40x25 mm
Mounting	Included: 2x M3x25 mm zinc plated steel pozidrive pan head screws, self-tapping (PZ DIN 7500CZ) Mounting on flat surface only. Screw with care
Ingress Protection (IEC 60529)	IP67, IP69K (with IP69K mating connector)
Relative humidity	0 - 95% (non condensing, housing fully potted)
Weight	approx. 45 gram
Supply voltage	6 - 30 V dc
Polarity protection	Yes
Current consumption	≤ 25 mA
Operating temperature	$-40 \dots +60^\circ\text{C}$
Storage temperature	$-40 \dots +85^\circ\text{C}$
Measuring range	Factory defaults: $\pm 80^\circ$
Centering function	Yes (0°), range: $\pm 5^\circ$
Frequency response (-3dB)	0 - 0,7 Hz
Accuracy (overall @20°C)	0,3° typ. (0,5° max)
Offset error	not applicable after zeroing
Non linearity	not applicable
Sensitivity error	not applicable, Repeatability 0,2°
Resolution	0,1°
Temperature coefficient	$\pm 0,04^\circ/\text{K}$ typ.
Max mechanical shock	10.000g
Output	dual PNP
Output load	2x 500 mA continuously, Temperature protected, protected against back EMF
Short circuit protection	Yes, continuously
Boot time	< 100 ms
Programming options	by optional QG40N-configurator (switch points, delay times, filtering)

QG40N-KDXYh-080-ASP-CM-UL

2 independent PNP outputs:
 - Programmable switchpoints $\pm S$ (optional QG40N Configurator)
 - Operation zone: conducting
 - Critical zone: non-conducting
 - Unpowered sensor: non-conducting

Factory defaults:
 - Switchpoint $\pm S$ output X: $\pm 80^\circ$
 - Switchpoint $\pm S$ output Y: $\pm 80^\circ$
 - hysteresis: $0,5^\circ$
 - operation \blacktriangleright critical delay : 0,5 s
 - critical \blacktriangleright operation delay : 1 s

Transfer characteristic

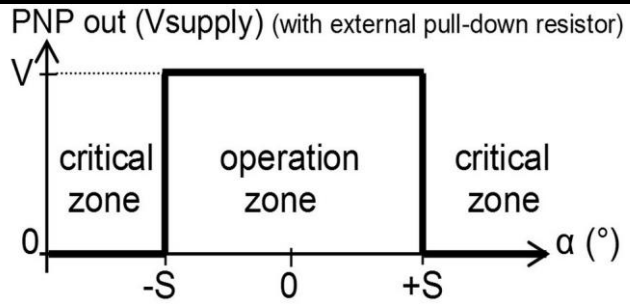

The default 0° position is when the sensor is mounted horizontally (round nose upwards) and no acceleration is applied.

Only one axis may exceed 45° tilt.

Zeroing: eliminate mech. offsets
 Connect zeroing input to ground ($>0,5\text{sec}$) within 1 min. after power up. Normally the zeroing input should be left unconnected.

Zeroing is possible within $\pm 5^\circ$ tilt.

Measurement orientation

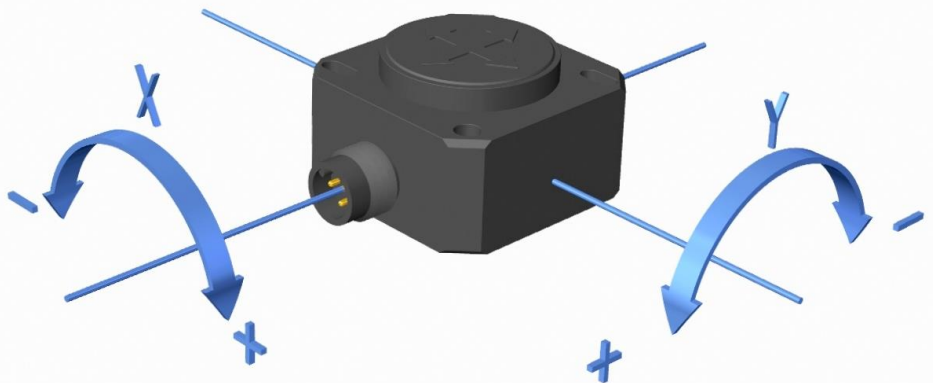

Connectivity (cable length $\pm 10\%$)

Connection

Wire / pin coding

M12 5p male connector (Glass fibre reinforced grade, contacts CuZn pre-nickeled galv. Au)

Pin 1: + Supply Voltage
 Pin 2: output Y
 Pin 3: Gnd
 Pin 4: output X
 Pin 5: zeroing

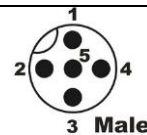

If connected with M12 F (accessory sold by DIS):

Brown: + Supply Voltage
 White: output Y
 Blue: Gnd
 Black: output X
 Green/yellow: zeroing

Mechanical dimensions (indicative only)

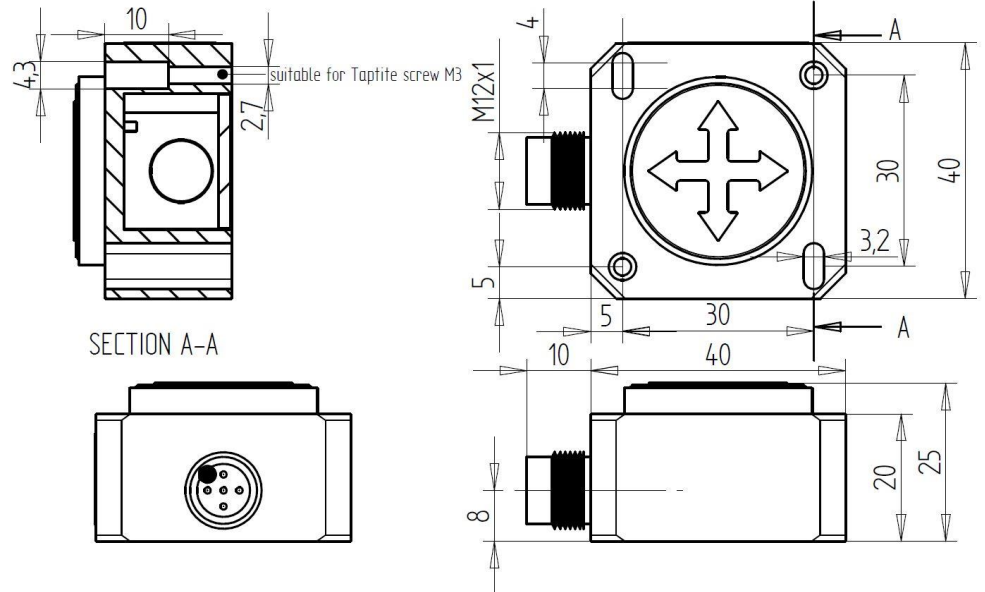

Intended use, UL, Remarks

QG series sensors are intended to measure inclination, acceleration or tilt angle after installing in machines, equipment and systems. Flawless function in accordance with the specifications is ensured only when the device is used within its specifications.

This device is not a safety component according to the EU Machine Directive (ISO13849). For full redundancy two devices can be used in the application.

Modifications or non-approved use are not permitted and will result in loss of warranty and void any claims against the manufacturer.

UL & c-UL listed product (File number E312057, UL508 standards UL60947-5-2 & CSA-C22,2 No. 14)

Product Identity / Category Code Number (CCN): Industrial Control Equipment / NRKH & NRKH7

Enclosure rating: type 1, Ambient temperature: max 80 °C (see also datasheet, lowest value applies)

Electrical ratings: Intended to be used with a Class 2 power source in accordance with UL1310,

max. input Voltage 32V dc (see also datasheet, lowest value applies), max. current 200mA

Accessory Cable Assembly: Any UL-listed (CYJV/7) mating connector with mechanical locking, wire thickness of at least 30 AWG (0,05 mm²), recommended ≤23 AWG (≥0,25 mm²)

As this device is accelerometer-based the sensor is inherent sensitive for accelerations/vibrations.

Application specific testing must be carried out to check whether this sensor will fulfil your requirements.