

QG40N-series

QG40N-KDXYh-090-AV-CM-UL

Inclination sensor

2 axis horizontal mounting

Programmable device

Output: 0,5 - 4,5 V

Measuring range programmable
between $\pm 1^\circ$ and $\pm 90^\circ$

Measuring range
Factory defaults: $\pm 90^\circ$

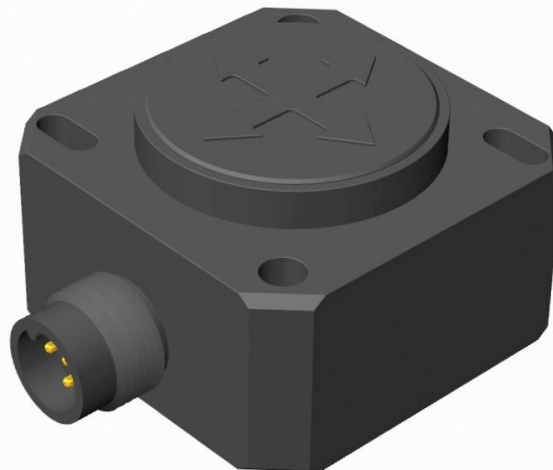

General specifications 11740B, v20241216

Housing	Plastic injection molded housing (Arnite T06 202 PBT black)
Dimensions (indicative)	40x40x25 mm
Mounting	Included: 2x M3x25 mm zinc plated steel pozidrive pan head screws, self-tapping (PZ DIN 7500CZ) Mounting on flat surface only. Screw with care
Ingress Protection (IEC 60529)	IP67, IP69K (with IP69K mating connector)
Relative humidity	0 - 95% (non condensing, housing fully potted)
Weight	approx. 45 gram
Supply voltage	6 - 30 V dc
Polarity protection	Yes
Current consumption	≤ 15 mA
Operating temperature	$-40 \dots +80$ °C
Storage temperature	$-40 \dots +85$ °C
Measuring range	Factory defaults: $\pm 90^\circ$
Centering function	Yes ($2,5$ V = 0°), range: $\pm 5^\circ$
Frequency response (-3dB)	0 - 10 Hz
Accuracy (overall @20°C)	$0,5^\circ$ typ.
Offset error	$\pm 0,2^\circ$ typ. after centering
Non linearity	$\pm 0,4^\circ$ typ.
Sensitivity error	not applicable. Repeatability $0,2^\circ$
Resolution	$0,1^\circ$
Temperature coefficient	$\pm 0,04^\circ/\text{K}$ typ.
Max mechanical shock	10.000g
Output	0,5 - 4,5 V
Output load	Rload $\geq 20\text{k}\Omega$, Cload ≤ 20 nF
Short circuit protection	Yes (max 10 s)
Output refresh rate	20 ms
Programming options	by optional QG40N-configurator (measuring range, filtering)

QG series

QG40N-KDXYh-090-AV-CM-UL

$V_{out} = 2,5 + 2 \cdot (\alpha/90)$ [V]
clipping outside measuring range

Centering: eliminate mech. offsets
Connect center input to ground (>0,5sec) within 1 min. after power up. Normally the center input should be left unconnected.

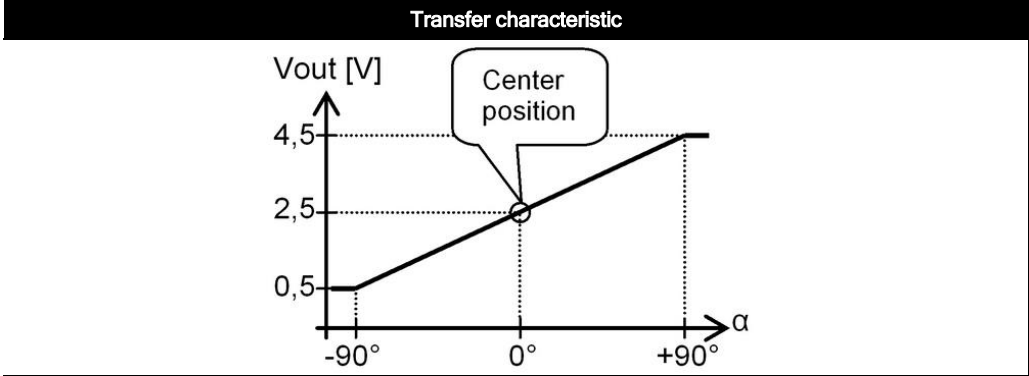

Default 0°: horizontal (round nose upwards), no acceleration applied.

Cross tilt sensitivity error:
< $(0,12 \cdot \text{cross tilt angle})^2$ % typ.

→ one axis <10° tilt for max. accuracy
→ only one axis may exceed 45° tilt

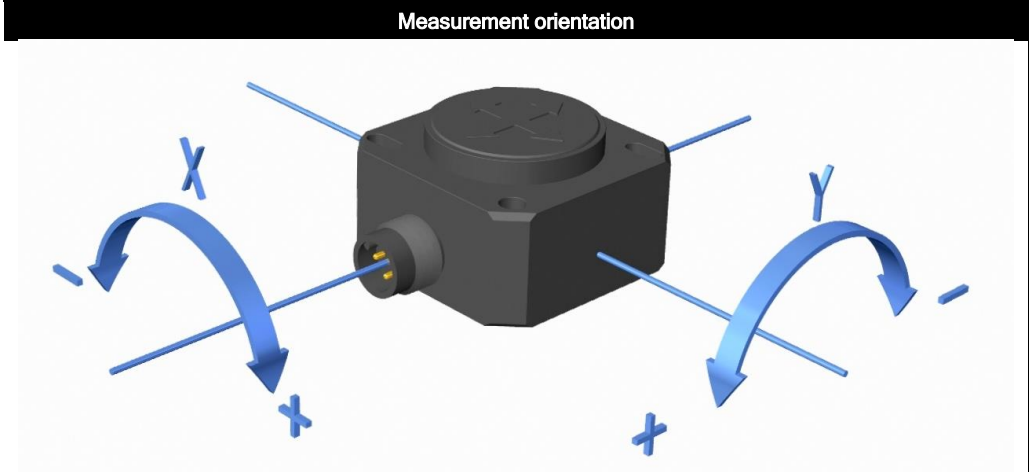

Connection

Wire / pin coding

Connectivity (cable length ±10%)

M12 5p male connector (Glass fibre reinforced grade, contacts CuZn pre-nickeled galv. Au)

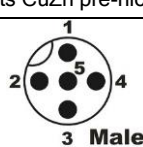
Pin 1:	+ Supply Voltage	
Pin 2:	output Y	
Pin 3:	Gnd	
Pin 4:	output X	
Pin 5:	centering	

If connected with M12 F (accessoire sold by DIS):

Brown:	+ Supply Voltage
White:	output Y
Blue:	Gnd
Black:	output X
Green/yellow:	centering

Mechanical dimensions (indicative only)

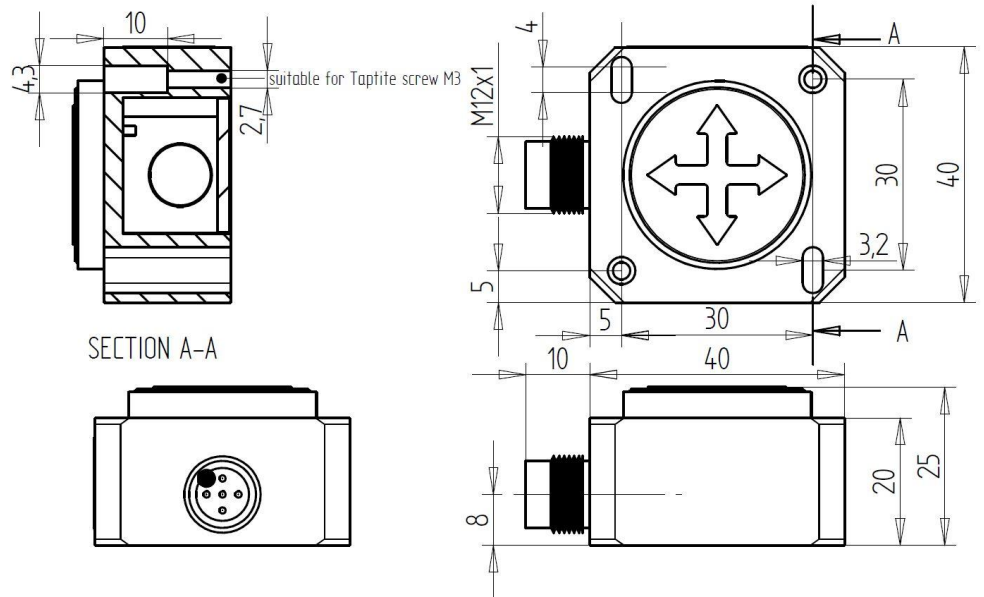

Intended use, UL, Remarks

QG series sensors are intended to measure inclination/acceleration/tilt. Flawless function (acc. spec.) is ensured only when used within specifications. This device is not a safety component acc. to EU Machine Directive (ISO13849). For full redundancy two devices can be used. Modifications or non-approved use will result in loss of warranty and void any claims against the manufacturer.

UL & c-UL listed product (File number E312057, UL508 standards UL60947-5-2 & CSA-C22,2 No. 14)
 Product Identity / Category Code Number (CCN): Industrial Control Equipment / NRKH & NRKH7
 Enclosure rating: type 1, Ambient temperature: max 80 °C (see also datasheet, lowest value applies)
 Electrical ratings: Intended to be used with a Class 2 power source in accordance with UL1310, max. input Voltage 32V dc (see also datasheet, lowest value applies), max. current 200mA
 Accessory Cable Assembly: Any UL-listed (CYJV/7) mating connector with mechanical locking, wire thickness of at least 30 AWG (0,05 mm²), recommended ≤23 AWG (≥0,25 mm²)

As this device is accelerometer-based the sensor is inherent sensitive for accelerations/vibrations. Application specific testing must be carried out to check whether this sensor will fulfil your requirements.