

QG series

QG65 X-series

QG65-KI-360X-CAN-C(F)M-T
Inclination sensor 1 axis vertical mounting
Programmable device Interface: CANopen
Active Temp. compensation by internal heater
Measuring range 360°

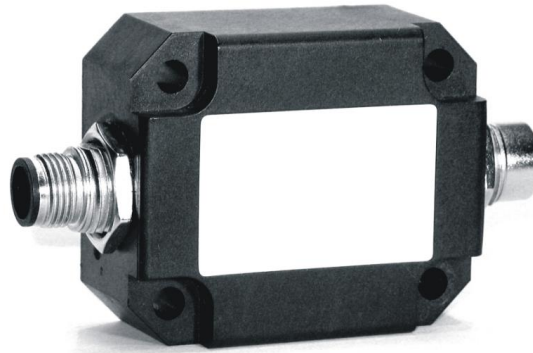

General specifications v20171107	
Housing	Reinforced plastic injection molded (Faradex DS, black, EMI shielded by stainless steel fiber in PC)
Dimensions (indicative)	60x50x27 mm
Mounting	4x M5x25 mm zinc plated pozidrive screws included
Ingress Protection (IEC 60529)	IP67
Relative humidity	0 - 100%
Weight	approx. 110 gram
Supply voltage	10 - 30 V dc
Polarity protection	Yes
Current consumption	≤ 75 mA (ambient Temp. 20°) Max.: 550mA (@24V), 275mA (@12V)
Operating temperature	-40 .. +85 °C
Storage temperature	-40 .. +85 °C
Measuring range	360°
Centering function	Yes (CANout 0 = 0°), range: 360°
Frequency response (-3dB)	0 - 10 Hz
Accuracy (typ. and/or 2σ)	overall 0,04° typ. @ stabilized Temperature (ambient Temp. -40° .. +30°C)
Offset error	< ± 0,01° max. after centering
Non linearity	< ± 0,04° typ. (< ± 0,06° max.)
Sensitivity error	not applicable
Resolution	0,001°
Temperature coefficient	0°/K (-40°C .. +30°C) ± 0,005°/K typ. (outside above specified range)
Max mechanical shock	20.000g
CAN interface (hardware)	CAN 2.0 A and B according to ISO 11898-1 & ISO 11898-2
CAN communication profile	CANopen, CiA301 V4.2.0 & EN 50325-4 + Device Profile CiA410 DSP 2.0.0
Baud rate	50, 125 (default), 250, 500, 1000 kbit/s
Node Id	01h (range: 01h - 7Fh)
TPDO	TPDO2: 281h (for Node ID=01h), TPDO1: 181h (for Node ID=01h)
Event time	TPDO2: 10 - 500 ms (default: 100 ms)
Sync mode	On/off (default: off)
Heartbeat	On/off (default: on, 2 sec.)
Programming options	Baudrate, Node Id, Event time, Sync mode, Heartbeat, Output format, Temp. setpoint
Output format	Sensor Temp. (PDO1:byte 2,1), Angle: -179.999 to 180.000 (PDO2:byte 4,3,2,1)
Temperature compensation	Yes, active Temperature compensation
Filtering	Input filter enabled, output filter disabled
Modes of operation	Event mode, Sync-mode
Temperature setpoint	30°C (range 0°C - 70°C), heating only
Boot time / Warming up time	< 1 s / 4min @ -10°C & 24 V
Programming options	by CANopen object dictionary (CAN parameters, heater, filtering)

QG65-KI-360X-CAN-C(F)M-T

CANoutput = $1000 \cdot \alpha$

clipping outside measuring range

Centering can be done to eliminate mechanical offsets. (can be done by CAN object 300Fh)
The current sensor position will be stored as the new Center position in the internal Eeprom.

Transfer characteristic

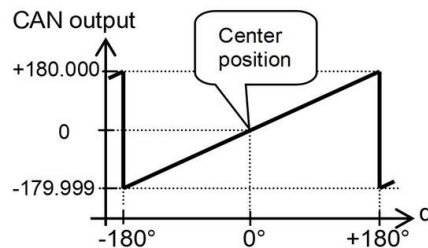

Rotation in vertical plane.

Lateral tilt sensitivity error:
$\pm 0,03^\circ$ lateral tilt (typ.)
Max. lateral tilt: 45°

Drawn in the default 0° position.

Measurement orientation

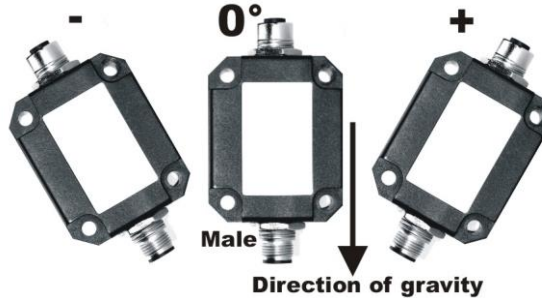

Connectivity (length $\pm 10\%$)

Male only or Male & Female (internal T-junction) M12 connector (5 pins, A-coding)
(CiA303 V1.8.0) (Brass Nickel coated, contacts copper alloy)

No bus termination inside. A CANbus always has to be terminated properly. For bus termination order separate M12 termination resistor (optional: T-connector)

Pin 1: Shield
Pin 2: Vcc
Pin 3: Gnd & CAN_GND
Pin 4: CAN_H
Pin 5: CAN_L

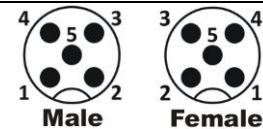

Connection

Wire / pin coding

Mechanical dimensions (indicative only)

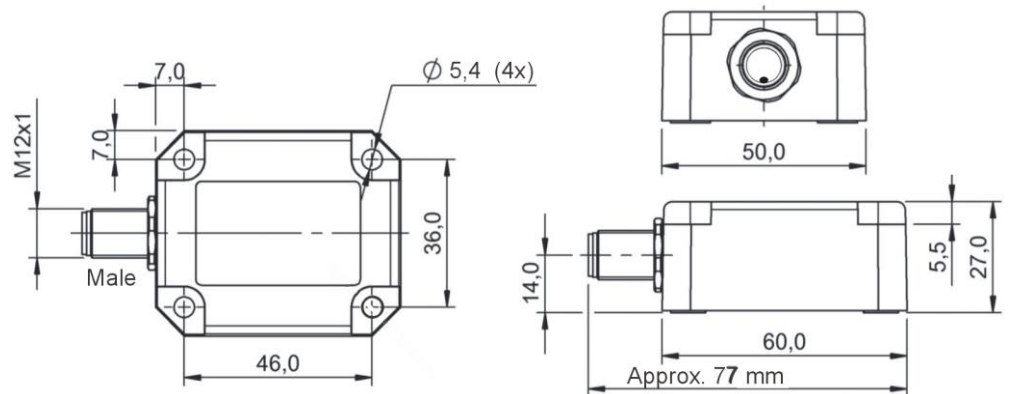

Center function, CAN-manual, EDS-file

This device has a build-in heater for active temperature compensation. The factory default setpoint is $+30^\circ\text{C}$. Therefore the Temperature coefficient between -40°C and $+30^\circ\text{C}$ is $0^\circ/\text{K}$. Above 30°C this value is specified in this datasheet.

Setting the setpoint $>30^\circ$ is possible (up to $+70^\circ\text{C}$) but this higher value will lead to some long-term-drift. Periodical centering (i.e. monthly) is recommended to eliminate this effect.

CAN-manual: E-type (available on request)

EDS-file (CiA306 V1.3.0): Etype (available on request)

Ordering codes:

M12 Male (11915): QG65-KI-360X-CAN-CM-T

M12 Male & Female (12613): QG65-KI-360X-CAN-CFM-T