

SIL2 / PLd Certified sensor

QG65N-KAXYZ-8-CANS-C(F)M-2d

Safety acceleration sensor

3 axis
horizontal/vertical mounting
(RMS or Signed Peak value)

Programmable device
Interface: CANopen Safety

SIL CL 2 (acc. to IEC 62061)
PLd (acc. to EN ISO 13849)

Measuring range
 ± 8 g



CANopen
safety easy to use



General specifications v20180125

Reinforced plastic injection molded (Faradex DS, black, EMI shielded by stainless steel fiber in PC)

60x50x27 mm

4x M5x25 mm zinc plated pozidrive screws included (optional: 2x Ø4mm positioning pins)

IP67

0 - 100%

approx. 110 gram

8 - 60 V dc SELV

Yes

≤ 75 mA

-40 .. +85 °C

-40 .. +85 °C

± 8 g

Yes, 2 horizontal axes only, (CANout 0 = 0 g), range: $\pm 5^\circ$

1600 Hz

Range $\pm 1/2/4/8$ g: overall 0,02/0,04/0,08/0,16 g typ.

$< \pm 0,5$ mg typ. ($< \pm 1,5$ mg max.) after zeroing

$< \pm 0,4\%$ full scale

$< \pm 2\%$

0,002 g

$\pm 0,3$ mg/K typ.

10.000 g

According to ISO 11898-1 & ISO 11898-2 (also known as CAN 2.0 A/B)

CANopen Safety protocol: EN 50325-5, CANopen protocol: EN 50325-4 (CiA 301 v4.0 & 4.2.0)

125 kbit/s (default, range 10/20/50/100/125/250/500/800/1000 kbit/s)

01h (default, range: 01h - 3Fh) (01h - 7Fh with adapted COB-ID's)

50 ms (default, range 10-500 ms)

off (default, range on/off)

+AC945 Integer: -8000 to +8000 (SRDO:X=byte 2,1; Y=byte 4,3; Z=byte 6,5) (byte 7,8: integer 0)

FFh + 2x node ID (for Node ID=01h: SRDO1 COB-ID1=101h) (range 101h - 180h)

100h + 2x node ID (for Node ID=01h: SRDO1 COB-ID2=102h) (range 101h - 180h)

80ms in CAN object dictionary, worst case 100ms

20ms

Output filter disabled

Emergency message 080h+Node-ID followed by NMT stop state (no CAN communication)

< 1 s

by CANopen object dictionary (CAN parameters, filtering)

Housing	
Dimensions (indicative)	
Mounting	
Ingress Protection (IEC 60529)	
Relative humidity	
Weight	
Supply voltage	
Polarity protection	
Current consumption	
Operating temperature	
Storage temperature	
Measuring range	
Centering function	
Frequency response (-3dB)	
Accuracy (typ. and/or 2σ)	
Offset error	
Non linearity	
Sensitivity error	
Resolution	
Temperature coefficient	
Max mechanical shock	
CAN interface (hardware)	
CANopen application layer and communication profile	
Baud rate	
Node Id	
TPDO1 event time	
Sync mode (TPDO's), Heartbeat	
Output format	
SRDO1 COB-ID1	
SRDO1 COB-ID2	
Safeguard cycle time (SCT)	
Safety related validation time (SRVT)	
Filtering	
Reaction on error	
Boot time	
Programming options	

QG series

QG65N-KXYZ-8-CANS-C(F)M-2d

Transfer characteristic

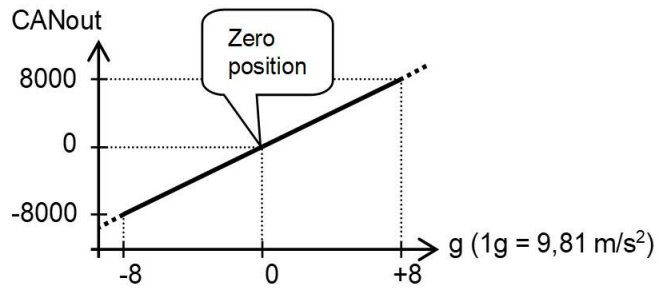

CANoutput = 1000*g

No clipping outside measuring range

Measurement orientation

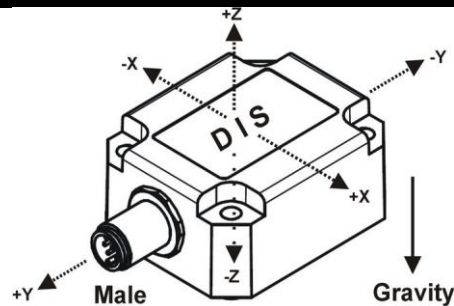

The default 0 g position is when the sensor is mounted horizontal or vertical and no acceleration is applied. The axis parallel to earth gravity will indicate 1 g, the two horizontal axes will indicate 0 g. The two horizontal axes can be zeroed within $\pm 5^\circ$ tilt (by the CAN object dictionary) to eliminate mounting offsets.

The axis parallel to earth gravity cannot be zeroed.

Optional the axis parallel to earth gravity can be compensated for 1 g gravity by the CAN object dictionary

Output value: RMS (default) or Signed Peak (selectable by CAN object dict.)

Connectivity (length $\pm 10\%$)

Male only or Male & Female (internal T-junction) M12 connector (5 pins, A-coding) (CiA303 V1.8.0) (Brass Nickel coated, contacts copper alloy)

No bus termination inside. A CANbus always has to be terminated properly. For bus termination order separate M12 termination resistor (optional: T-connector)

Pin 1: Shield
 Pin 2: Vcc
 Pin 3: Gnd & CAN_GND
 Pin 4: CAN_H
 Pin 5: CAN_L

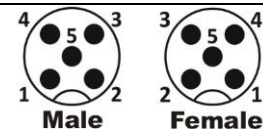

Connection

Wire / pin coding

Mechanical dimensions (indicative only)

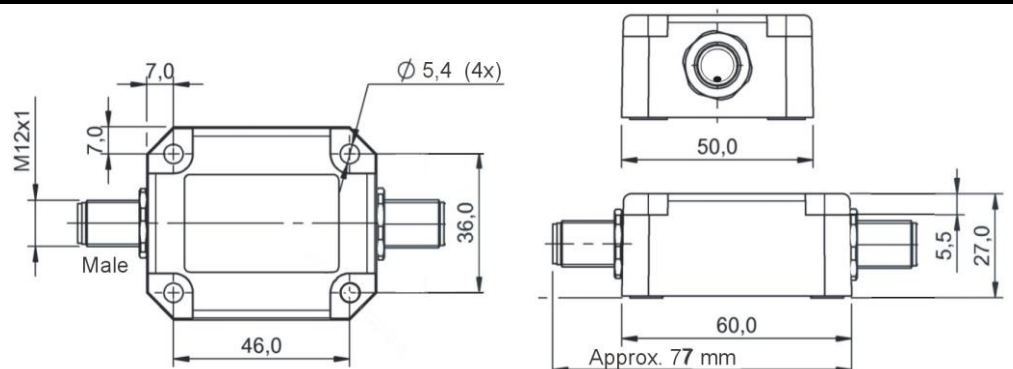

QG65N-KAXYZ-8-CANS-C(F)M-2d

CAN-manual, EDS-file, Safety information, Ordering codes

A CANopen-safety manual, EDS-files (CiA306 V1.3.0) and a Declaration of Conformity are available on www.dis-sensors.com/downloads

Safety information:

- this datasheet + relevant manual must be read and understood before using this safety device
- certified level: SIL CL 2 (acc. to IEC 62061), PLd (acc. to EN ISO 13849)
- EC type examination by DEKRA EXAM GmbH Reg. no.: ZP/C015/16
- hardware architecture: HFT=0 (according IEC 62061, CAT.2 (according to EN ISO 13849)
- Standard (-40°C to +45°C): MTTFd: 447 year, DC: 93%, CCF: 70 pt, SFF: 98%, PFHd: 14E-09
- High Temp. (up to +85 °C): MTTFd: 73 year, DC: 93%, CCF: 70 pt, SFF: 98%, PFHd: 91E-09
- only a SELV power supply should be used
- Redundancy Compare Time (error if this time is expired): customer adjustable (default 2000ms)
- Redundancy Compare Acceleration (error if acceleration-difference > this value): customer adjustable (default 580mg)
- Redundancy error: Redundancy Compare Angle & Redundancy Compare Time exceeded
- Error: any detected error or a redundancy error
- Safety Related Fault Respons Time (SRFRT): 100ms + Redundancy Compare Time (default 2000ms)

This sensor is inherent sensitive for accelerations/vibrations.

Application specific testing must be carried out to check whether this sensor will fulfil your requirements.

Ordering codes:

M12 Male: QG65N-KAXYZ-8,0-CANS-CM-2d

M12 Male & Female: QG65N-KAXYZ-8,0-CANS-CFM-2d, 12205