

QG76N CAN series

QG76N-SIXv-360-CAN-C(F)M

Inclination sensor

1 axis vertical mounting

Programmable device

Interface: CANopen

Parameters programmable
by CANopen object dictionary

Measuring range
360°

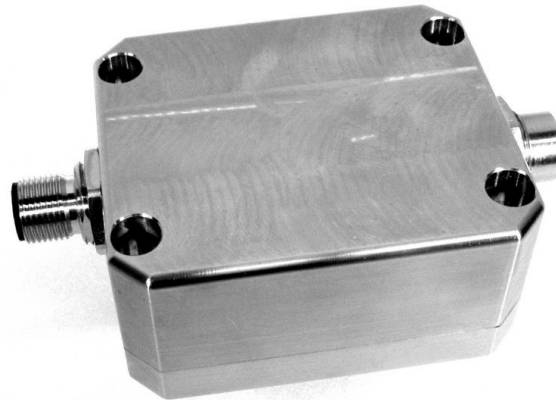

CANopen



General specifications v20190325

Housing	Stainless steel (AISI 316)
Dimensions (indicative)	70x60x33 mm
Mounting	Included: 4x M4x30 mm stainless steel (A4) Hexagon socket head screws
Ingress Protection (IEC 60529)	IP67 (IP68 with optional cable gland)
Relative humidity	0 - 100%
Weight	approx. 700 gram
Supply voltage	8 - 30 V dc
Polarity protection	Yes
Current consumption	≤ 50 mA
Operating temperature	-40 .. +85 °C
Storage temperature	-40 .. +85 °C
Measuring range	360°
Centering function	Yes (CANout 0 = 0°), range: 360°
Frequency response (-3dB)	0 - 20 Hz
Typ. Accuracy @20°C (2σ)	overall 0,15° typ.
Offset error	< ± 0,05° typ. (< ± 0,1° max.) after centering
Non linearity	< ± 0,1° typ. (< ± 0,2° max.)
Sensitivity error	not applicable
Resolution	0,05°
Temperature coefficient	± 0,01°/K typ.
Max mechanical shock	10.000 g
CAN interface (hardware)	According to ISO 11898-1 & ISO 11898-2 (also known as CAN 2.0 A/B)
CANopen application layer and communication profile	CANopen protocol: EN 50325-4 (CiA 301 v4.0 & and v4.2.0)
Baud rate	125 kbit/s (default), 250 kbit/s, 500 kbit/s, 1Mbit/s
Node Id	01h (range: 01h - 7Fh)
TPDO	TPDO1: 181h (for Node ID=01h)
Event time	TPDO1: 5 - 500 ms (default: 100 ms)
Sync mode	On/off (default: off)
Heartbeat	On/off (default: on, 2s)
Programming options	Baudrate, Node Id, Event time, Sync mode, Heartbeat, Output format
Output format	Integer: -17999 to +18000 (PDO1:byte 2,1)
Filtering	Input filter enabled, output filter disabled
Modes of operation	Event mode, Sync-mode
Boot time	< 1 s
Programming options	by CANopen object dictionary (CAN parameters, filtering)

QG76N-SIXv-360-CAN-C(F)M

CANoutput = 100*α

Transfer characteristic

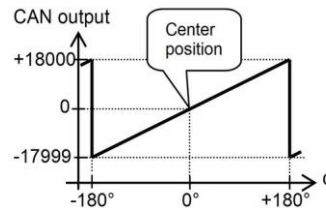

Rotation in vertical plane.

Lateral tilt sensitivity error:
 $\lt; \pm 0,03^\circ$ lateral tilt (typ.)
 Max. lateral tilt: 45°

Drawn in the default 0° position.

Measurement orientation

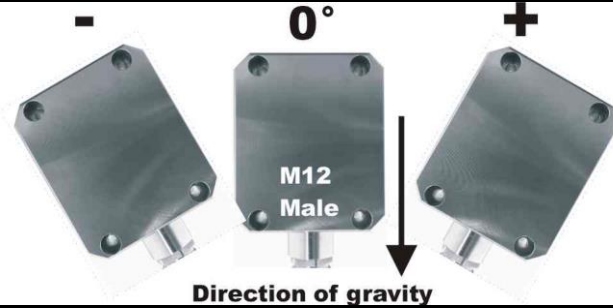

Direction of gravity

Connectivity (length $\pm 10\%$)

Male only or Male & Female (internal T-junction) M12 connector (5 pins, A-coding)
 (CiA303 V1.8.0) (stainless steel 1.4404 (316L), contacts copper alloy)

No bus termination inside. A CANbus always has to be terminated properly. For bus termination order separate M12 termination resistor (optional: T-connector)

Connection

Pin 1:	Shield
Pin 2:	Vcc
Pin 3:	Gnd & CAN_GND
Pin 4:	CAN_H
Pin 5:	CAN_L

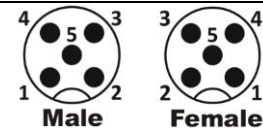

Wire / pin coding

Mechanical dimensions (indicative only)

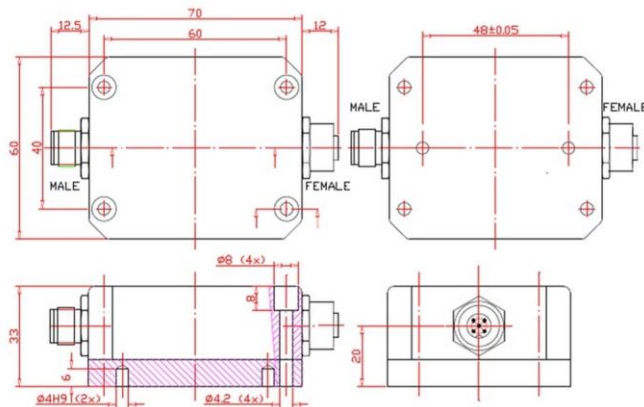

Center function, CAN-manual, EDS-file, Ordering codes

Centering can be done to eliminate mechanical offsets. (can be done by CAN object 300Fh)
 The current sensor position will be stored as the new Center position in the internal Eeprom.

A CAN-manual is available at www.dis-sensors.com, see 'downloads'

EDS-file (CiA306 V1.3.0) is available at www.dis-sensors.com, see 'downloads'

As this device is accelerometer-based the sensor is inherent sensitive for accelerations/vibrations.
 Application specific testing must be carried out to check whether this sensor will fulfil your requirements.

Ordering codes:

M12 Male: QG76N-SIXv-360-CAN-CM

M12 Male & Female: QG76N-SIXv-360-CAN-CFM