

QG series

QG40N-series

QG40N-KAXYh-16,0-AV-CM-UL

Acceleration sensor

2 axis horizontal mounting

Programmable device

Output: 0,5 - 4,5 V

Measuring range programmable
between 0,1 g and 16 g

Measuring range
Factory defaults: ± 16 g

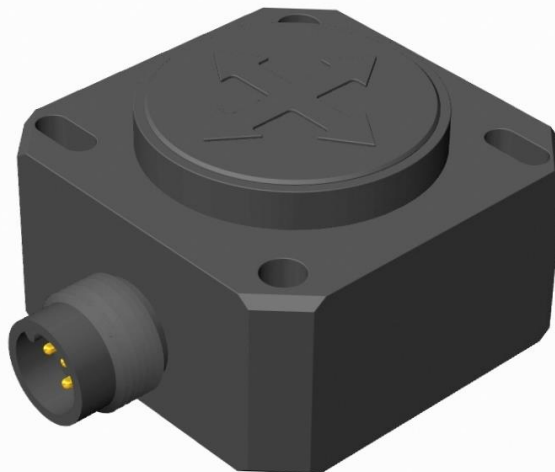

General specifications 12320, v20230725

Housing	Plastic injection molded housing (Arnite T06 202 PBT black)
Dimensions (indicative)	40x40x25 mm
Mounting	Included: 2x M3x25 mm zinc plated steel pozidrive pan head screws, self-tapping (PZ DIN 7500CZ) Mounting on flat surface only. Screw with care
Ingress Protection (IEC 60529)	IP67, IP69K (with IP69K mating connector)
Relative humidity	0 - 95% (non condensing, housing fully potted)
Weight	approx. 45 gram
Supply voltage	6 - 30 V dc
Polarity protection	Yes
Current consumption	≤ 15 mA
Operating temperature	-40 .. +80 °C
Storage temperature	-40 .. +85 °C
Measuring range	Factory defaults: ± 16 g
Centering function	Yes (2,5 V = 0 G), range $\pm 5^\circ$
Frequency response (-3dB)	0 - 50 Hz
Accuracy (overall @20°C)	overall 0,5 g typ.
Offset error	± 30 mg typ. (± 60 mg 2σ) after zero adjustment
Non linearity	$\pm 0,04$ g typ.
Sensitivity error	$\pm 2\%$ typ.
Resolution	10 mg
Temperature coefficient	± 1 mg/K typ.
Max mechanical shock	10.000g
Output	0,5 - 4,5 V
Output load	Rload $\geq 20k\Omega$, Cload ≤ 20 nF
Short circuit protection	Yes (max 10 s)
Output refresh rate	3 ms
Programming options	by optional QG40N-configurator (measuring range, filtering)

QG40N-KAXYh-16,0-AV-CM-UL

Transfer characteristic

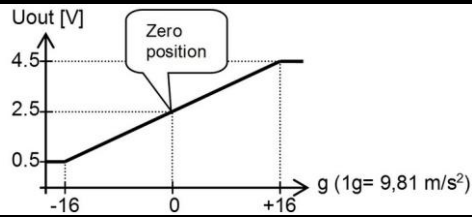

$U_{out} = 2,5 + g/8$ [V]
clipping outside measuring range

Zeroing: eliminate mech. offsets
Connect zeroing input to ground (>0,5sec) within 1 min. after power up. Normally the zeroing input should be left unconnected.

Measurement orientation

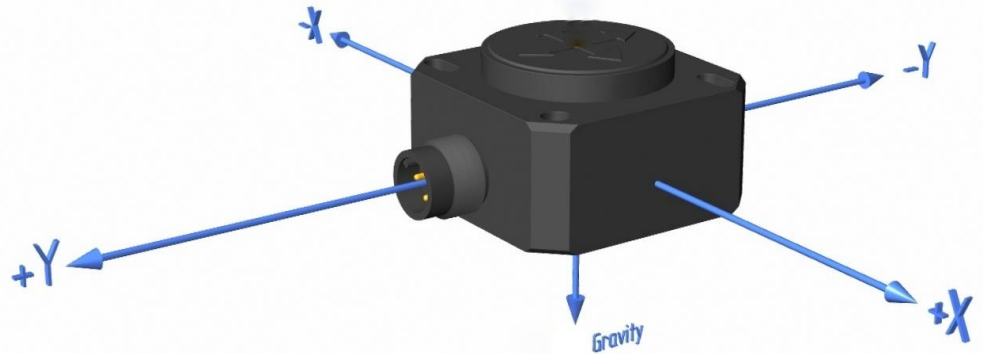

0 g when no acceleration applied

Horizontal mounting:
1-axis or 2-axis usage

Connect output-X and/or output-Y according the plot at the right.

Upside down mounting possible (sensor-nose down)

Connectivity (cable length $\pm 10\%$)

M12 5p male connector (Glass fibre reinforced grade, contacts CuZn pre-nickeled galv. Au)

Pin 1: + Supply Voltage
Pin 2: output Y
Pin 3: Gnd
Pin 4: output X
Pin 5: zeroing

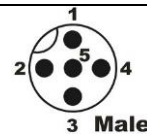

If connected with M12 F (accessory sold by DIS):

Brown: + Supply Voltage
White: output Y
Blue: Gnd
Black: output X
Green/yellow: zeroing

Connection

Wire / pin coding

Mechanical dimensions (indicative only)

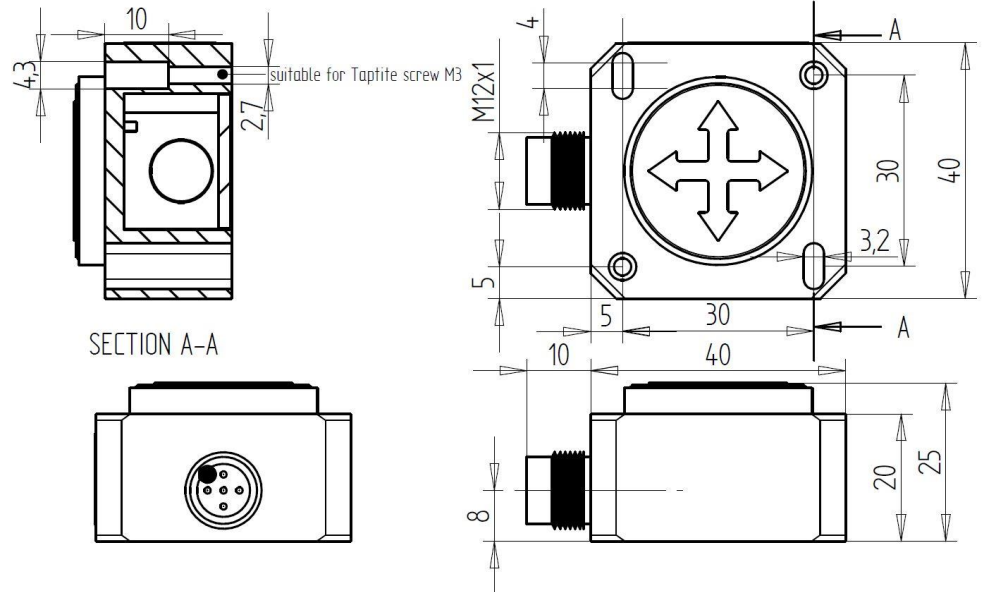

Intended use, UL, Remarks

QG series sensors are intended to measure inclination/acceleration/tilt. Flawless function (acc. spec.) is ensured only when used within specifications. This device is not a safety component acc. to EU Machine Directive (ISO13849). For full redundancy two devices can be used. Modifications or non-approved use will result in loss of warranty and void any claims against the manufacturer.

UL & c-UL listed product (File number E312057, UL508 standards UL60947-5-2 & CSA-C22,2 No. 14)
 Product Identity / Category Code Number (CCN): Industrial Control Equipment / NRKH & NRKH7
 Enclosure rating: type 1, Ambient temperature: max 80 °C (see also datasheet, lowest value applies)
 Electrical ratings: Intended to be used with a Class 2 power source in accordance with UL1310,
 max. input Voltage 32V dc (see also datasheet, lowest value applies), max. current 200mA
 Accessory Cable Assembly: Any UL-listed (CYJV/7) mating connector with mechanical locking, wire
 thickness of at least 30 AWG (0,05 mm²), recommended ≤23 AWG (≥0,25 mm²)

As this device is accelerometer-based the sensor is inherent sensitive for accelerations/vibrations.
 Application specific testing must be carried out to check whether this sensor will fulfil your requirements.