

QG65D CANopen Standard accuracy series

QG65D-KDXyh-030-CAN-C(F)M-UL
Dynamic Inclination sensor 2 axis horizontal mounting
Programmable device Interface: CANopen
Parameters programmable by DIS configurator and CANopen object dictionary
Measuring range $\pm 30^\circ$



General specifications 12818, 12821, v20241115	
Housing	Reinforced plastic injection molded (Faradex DS, black, EMI shielded by stainless steel fiber in PC)
Dimensions (indicative)	60x50x27 mm
Mounting	Included: 4x M5x25 mm zinc plated steel pozidrive pan head screws, self-tapping (PZ DIN7500CZ) Mounting on flat surface only. Screw with care
Ingress Protection (IEC 60529)	IP67, IP69K (with IP69K mating connector)
Relative humidity	0 - 95% (non condensing, housing fully potted)
Weight	approx. 110 gram
Supply voltage	10 - 32 V dc
Polarity protection	Yes
Current consumption	50mA typ. For CFM models (daisy-chained CANbus): max. current internal T-junction: 2.5A
Operating temperature	-40 .. +80 °C
Storage temperature	-40 .. +85 °C
Measuring range	$\pm 30^\circ$
Centering function	Yes (CANout 0 = 0°), range: $\pm 5^\circ$
Frequency response (-3dB)	0 - 50 Hz, Max angle rate 500°/s
Accuracy (overall @20°C)	0,15° typ. (static), 0,8° typ. (dynamic)
Offset error	$\pm 0,05^\circ$ typ. ($\pm 0,1^\circ$ 2 σ) after centering
Non linearity	Static: $\pm 0,1^\circ$ typ., $\pm 0,15^\circ$ 2 σ , $\pm 0,2^\circ$ max, Dynamic: $\pm 0,8^\circ$ typ. (*) (**)
Sensitivity error	not applicable. Repeatability 0,1°
Resolution	0,01°
Temperature coefficient	T>0°C: 0.015°/K typ. en T<0°C: 0.03°/K typ.
Max mechanical shock	10,000g (max 0,2ms, non-repetitive)
CAN interface (physical layer)	According to ISO 11898-1 & ISO 11898-2 (CAN 2.0 A/B), Short circuit protected
CANopen application layer and communication profile	CANopen, CiA301 V4.2.0 & EN 50325-4 + Device Profile CiA410 DSP 2.0.0 for inclinometers
Baud rate	250 kbit/s (default, range 10/20/50/100/125/250/500/800/1000 kbit/s
Node ID	01h (range: 01h - 7Fh)
TPDO	For Node ID=01h: TPDO1: 181h, TPDO2: 281h
Event timer for TPDO1	TPDO1: 10 - 500 ms (default: 100 ms)
Sync mode	On/off (default: off)
Heartbeat	On/off (default: on, 2s)
Programming options	Baudrate, Node ID, Event time, Sync mode, Heartbeat, Output format, CANbus termination, filtering
Output format	Integer: -3000 to +3000 (TPDO1:data X=byte 2,1;Y=byte 4,3)
Application profiles	0/1/2/3 (factory default: profile 1)
Modes of operation	Event mode, Sync-mode. Default: auto-startup Event mode
Internal CANbus termination	120 Ohm on/off (default: off)
Boot time	< 0.5 s
Programming options	by Optional DIS Configurator set CAN and CANopen object dictionary (CAN parameters, application profiles, filtering)

QG series

QG65D-KDXYh-030-CAN-C(F)M-UL

CANoutput = 100*α

Clipping outside measuring range

Zeroing can be done to eliminate mounting offsets.

Default 0°: horizontal (label upwards), no acceleration applied. To eliminate mounting offsets the sensor can be zero-ed within ±5° tilt (by the CAN object dictionary)

Cross tilt sensitivity error:
 $< (0,12 * \text{cross tilt angle})^2 \% \text{ typ.}$

→ one axis <10° tilt for max. accuracy

Connection

Wire / pin coding

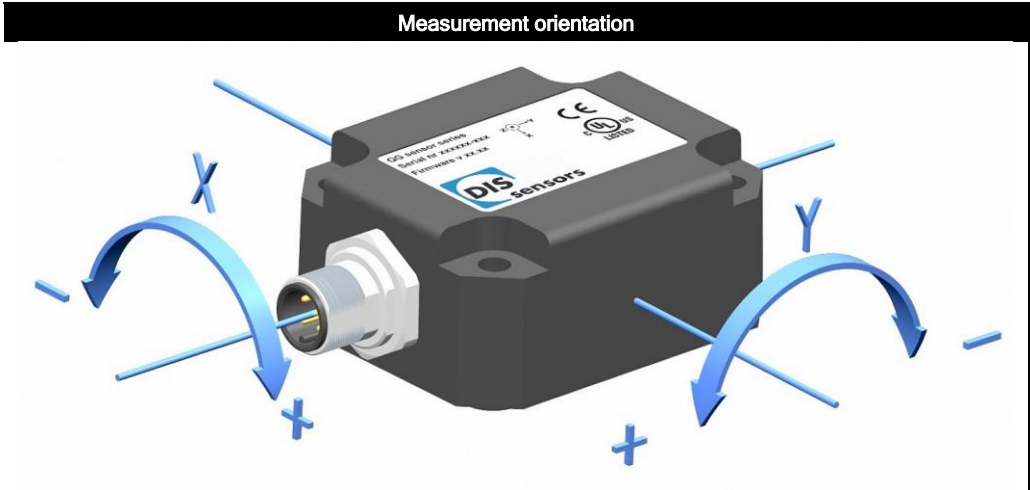
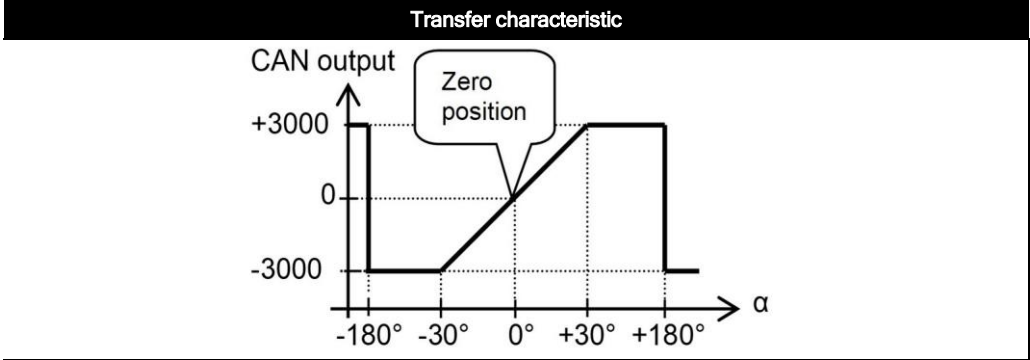

Connectivity (cable length ±10%)

Male only or Male & Female (internal T-junction) M12 connector (5 pins, A-coding) (CiA303 V1.8.0) (Brass Nickel coated, contacts copper alloy)

A CANbus always has to be terminated properly according to customers bus topology and general CAN rules. The sensor has an on-board internal 120 Ohm CANbus termination resistor that can be switched on by the CANopen dictionary (default: off). Alternatively an external M12 termination resistor can be connected when using a Male & Female (internal T-junction) model.

External M12 termination resistors and T-connectors are available as accessoires, see DIS website.

Pin 1:	Shield		
Pin 2:	Vcc		
Pin 3:	Gnd & CAN_GND		
Pin 4:	CAN_H		
Pin 5:	CAN_L		

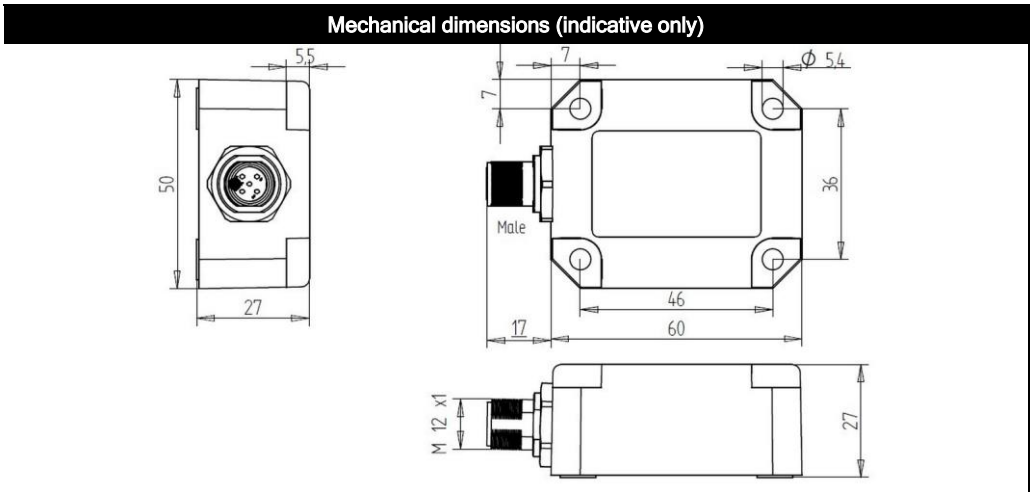

E4ready, UL, CAN-manual, EDS-file, Ordering codes

Before using this device, please read this datasheet, the Manual and the Declaration of Conformity carefully (download from dis-sensors.com)

This product is E4ready and meets Automotive EMC requirements

Connect this sensor only to an approved CAN controller which must have a grounded shield. Alternatively, connect the sensor housing to a grounded shield. All mentioned EMC standards that are met (see Declaration of Conformity) have been done with the housing connected to a grounded shield.

QG series sensors are intended to measure inclination/acceleration/tilt. Flawless function (acc. spec.) is ensured only when used within specifications. This device is not a safety component acc. to EU Machine Directive (ISO13849). For full redundancy two devices can be used. Modifications or non-approved use will result in loss of warranty and void any claims against the manufacturer.

UL & c-UL listed product (File number E312057, UL508 standards UL60947-5-2 & CSA-C22.2 No. 14)
Product Identity / Category Code Number (CCN): Industrial Control Equipment / NRKH & NRKH7
Enclosure rating: type 1, Ambient temperature: max 80 °C (see also datasheet, lowest value applies)
Electrical ratings: Intended to be used with a Class 2 power source in accordance with UL1310, max. input Voltage 32V dc (see also datasheet, lowest value applies), max. current 200mA
Accessory Cable Assembly: Any UL-listed (CYJV/7) mating connector with mechanical locking, wire thickness of at least 30 AWG (0,05 mm²), recommended ≤23 AWG (≥0,25 mm²)

(*) Accuracy within spec : approx.. 30sec after boot-up.

(**) Dynamic accuracy figures based on Robot tests, robot performing actions representative for general mobile machine movements

Optional: for accurate mounting two factory mounted positioning pins can be mounted (Ø4mm) replacing 2x M5x25 mm.

As this device is accelerometer-based the sensor is inherent sensitive for accelerations/vibrations. The majority of these dynamic effects will be eliminated by the on-board gyroscope. The on-board gyroscope and Kalman filtering are special designed to prevent the inclinometer to become significant inaccurate in dynamic situations. The sensor has pre-programmed Kalman algorithms ('Application profiles') that can be selected via the CANbus
Application specific testing must be carried out to check which compensation algorithm fits the application best, and whether this sensor will fulfil customers requirements.

A CAN-manual and EDS-file (CiA306 V1.3.0) can be downloaded from the website (Type H)

Ordering codes:

M12 Male: QG65D-KDXYh-030-CAN-CM-UL, 12818

M12 Male & Female: QG65D-KDXYh-030-CAN-CFM-UL, 12821