

QG65D SAE J1939 Standard accuracy series

QG65D-KDXyh-030-CANJ-C(F)M-UL

Dynamic Inclination sensor 2 axis horizontal mounting

Programmable device
Interface: CAN SAE J1939

Parameters programmable
by J1939

Measuring range
 $\pm 30^\circ$

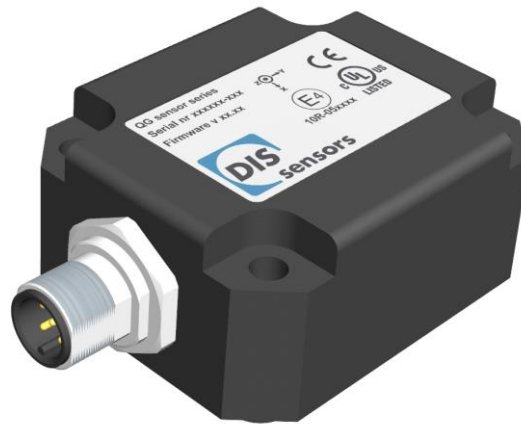

General specifications v20211130

Housing	Reinforced plastic injection molded (Faradex DS, black, EMI shielded by stainless steel fiber in PC)
Dimensions (indicative)	60x50x27 mm
Mounting	Included: 4x M5x25 mm zinc plated steel pozidrive pan head screws, self-tapping (PZ DIN7500CZ) (optional: Factory mounted 2x Ø4mm positioning pins replacing 2x M5x25 mm)
Ingress Protection (IEC 60529)	IP67, IP69K (with IP69K mating connector)
Relative humidity	0 - 95% (non condensing, housing fully potted)
Weight	approx. 110 gram
Supply voltage	10 - 32 V dc
Polarity protection	Yes
Current consumption	50mA typ. For CFM models (daisy-chained CANbus): max. current internal T-junction: 2.5A
Operating temperature	-40 .. +80 °C
Storage temperature	-40 .. +85 °C
Measuring range	$\pm 30^\circ$
Centering function	Yes (CANout 0 = 0°), range: $\pm 5^\circ$
Frequency response (-3dB)	0 - 100 Hz, Max angle rate 500°/s
Accuracy (overall @20°C)	0,15° typ. (static), 0,8° typ. (dynamic)
Offset error	$\pm 0,05^\circ$ typ. ($\pm 0,1^\circ$ max.) after centering
Non linearity	Static: $\pm 0.1^\circ$ typ., $\pm 0,15^\circ 2\sigma$, $\pm 0.2^\circ$ max, Dynamic: $\pm 0,8^\circ$ typ. (*) (**)
Sensitivity error	not applicable. Repeatability 0,1°
Resolution	0,01°
Temperature coefficient	T>0°C: 0.015°/K typ. en T<0°C: 0.03°/K typ.
Max mechanical shock	10,000g (max 0,2ms)
CAN interface	According to ISO 11898-1 & ISO 11898-2 (CAN 2.0 A/B), Short circuit protected
SAE J1939	SAE J1939
Baud rate	250 kbit/s (range 250/500kbit/s)
Default address	80h = 128dec
PGN	Inclination: FF00h = 65280dec, acceleration: FF03h = 65283dec
PGN cycle time	100ms
Priority	3 (default)
Output format	Integer: -3000 to +3000 (X=byte 1,0; Y=byte 3,2)
Internal CANbus termination	120 Ohm on/off (default: off)
Boot time	< 0.5 s
Programming options	J1939 parameters: baud rate, device address PGN, cycle time, priority. Sensor functions: internal CANbus termination

QG series

QG65D-KDXYh-030-CANJ-C(F)M-UL

J1939 output = $100 \cdot \alpha$
 Clipping outside measuring range

Default 0°: horizontal (label upwards), no acceleration applied. To eliminate mounting offsets the sensor can be zero-ed within $\pm 5^\circ$ tilt (by the CAN object dictionary)

Cross tilt sensitivity error:
 $< (0,12 \cdot \text{cross tilt angle})^2 \%$ typ.

→ one axis $< 10^\circ$ tilt for max. accuracy

Connection

Wire / pin coding

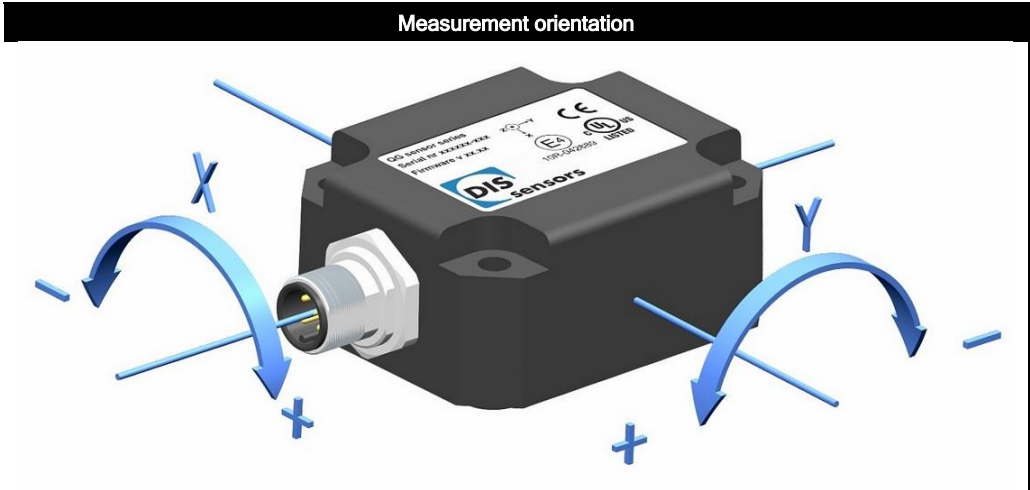
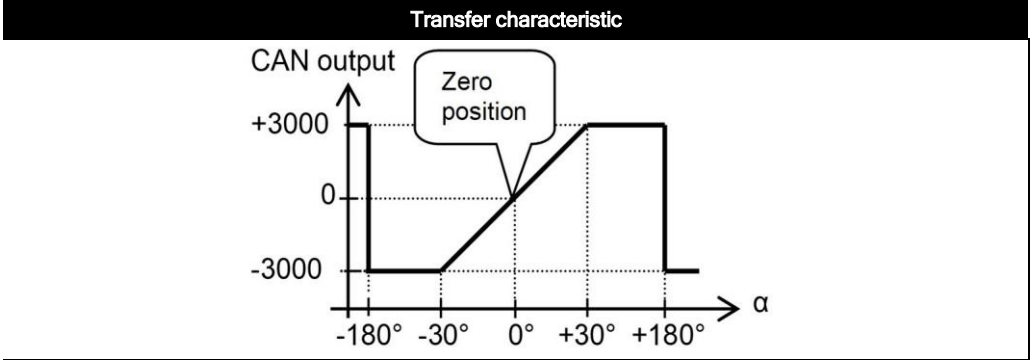

Connectivity (cable length $\pm 10\%$)

Male only or Male & Female (internal T-junction) M12 connector (5 pins, A-coding) (CiA303 V1.8.0) (Brass Nickel coated, contacts copper alloy)

A CANbus always has to be terminated properly according to customers bus topology and general CAN rules.
 The sensor has an on-board internal 120 Ohm CANbus termination resistor that can be switched on by the CANopen dictionary (default: off).
 Alternatively an external M12 termination resistor can be connected when using a Male & Female (internal T-junction) model.
 External M12 termination resistors and T-connectors are available as accessoires, see DIS website.

Pin 1:	Shield		
Pin 2:	Vcc		
Pin 3:	Gnd & CAN_GND		
Pin 4:	CAN_H		
Pin 5:	CAN_L	Male	Female

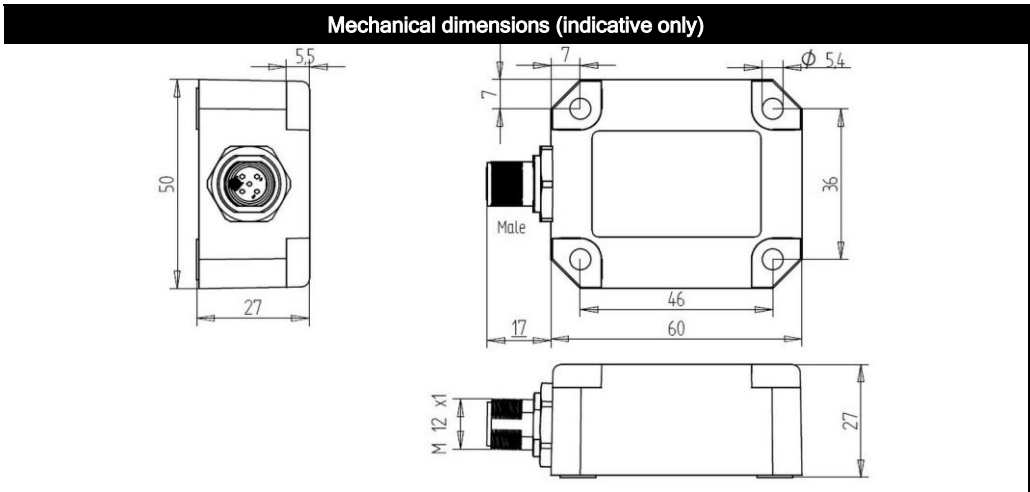

E4, UL, J1939-manual, Ordering codes

Before using this device, please read this datasheet, the Manual and the Declaration of Conformity carefully (download from dis-sensors.com)

This product is approved for automotive use, approval number: E4-10R-05-4662

Connect this sensor only to an approved CAN controller which must have a grounded shield. Alternatively, connect the sensor housing to a grounded shield. All mentioned EMC standards that are met (see Declaration of Conformity) have been done with the housing connected to a grounded shield.

QG series sensors are intended to measure inclination/acceleration/tilt. Flawless function (acc. spec.) is ensured only when used within specifications. This device is not a safety component acc. to EU Machine Directive (ISO13849). For full redundancy two devices can be used. Modifications or non-approved use will result in loss of warranty and void any claims against the manufacturer.

UL & c-UL listed product (File number E312057, UL508 standards UL60947-5-2 & CSA-C22.2 No. 14)
Product Identity / Category Code Number (CCN): Industrial Control Equipment / NRKH & NRKH7
Enclosure rating: type 1, Ambient temperature: max 80 °C (see also datasheet, lowest value applies)
Electrical ratings: Intended to be used with a Class 2 power source in accordance with UL1310, max. input Voltage 32V dc (see also datasheet, lowest value applies), max. current 200mA
Accessory Cable Assembly: Any UL-listed (CYJV/7) mating connector with mechanical locking, wire thickness of at least 30 AWG (0,05 mm²), recommended ≤23 AWG (≥0,25 mm²)

(*) Accuracy within spec : approx.. 30sec after boot-up.

(**) Dynamic accuracy figures based on Robot tests, robot performing actions representative for general mobile machine movements

As this device is accelerometer-based the sensor is inherent sensitive for accelerations/vibrations. The majority of these dynamic effects will be eliminated by the on-board gyroscope. The on-board gyroscope and Kalmann filtering are special designed to prevent the inclinometer to become significant inaccurate in dynamic situations. Application specific testing must be carried out to check which compensation algorithm fits the application best, and whether this sensor will fulfil customers requirements.

A 1939 manual can be downloaded from the website (Type JA)

Ordering codes: to be defined