

QG series



SIL2 / PLd Certified sensor

QG65N-KDXYh-030-CANS-C(F)M-UL-2d

Safety inclination sensor
2 axis horizontal mounting

Programmable device
Interface: CANopen Safety

SIL CL 2 (acc. to IEC 62061)
PLd (acc. to EN ISO 13849)

Measuring range
 $\pm 30^\circ$

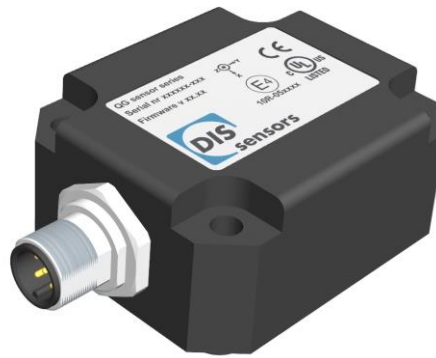

General specifications 12080/12083, v20230310

Housing	Reinforced plastic injection molded (Faradex DS, black, EMI shielded by stainless steel fiber in PC)
Dimensions (indicative)	60x50x27 mm
Mounting	Included: 4x M5x25 mm zinc plated steel pozidrive pan head screws, self-tapping (PZ DIN7500CZ) Mounting on flat surface only. Screw crosswise with maximum Torque 2.5 Nm
Ingress Protection (IEC 60529)	IP67, IP69K (with IP69K mating connector)
Relative humidity	0 - 95% (non condensing, housing fully potted)
Weight	approx. 110 gram
Supply voltage	8 - 32 V dc SELV
Polarity protection	Yes
Current consumption	≤ 25 mA For CFM models (daisy-chained CANbus): max. current internal T-junction: 2.5A
Operating temperature	$-40 \dots +80$ °C
Storage temperature	$-40 \dots +85$ °C
Measuring range	$\pm 30^\circ$
Centering function	Yes (CANout 0 = 0°), range: $\pm 5^\circ$
Frequency response (-3dB)	0 - 10 Hz
Accuracy (overall @20°C)	0,15° typ.
Offset error	$\pm 0,05^\circ$ typ. ($\pm 0,1^\circ$ 2 σ) after centering
Non linearity	$\pm 0,1^\circ$ typ., $\pm 0,15^\circ$ 2 σ , $\pm 0,2^\circ$ max.
Sensitivity error	not applicable. Repeatability 0,1°
Resolution	0.05°
Temperature coefficient	$\pm 0,02^\circ/\text{K}$ typ.
Max mechanical shock	10.000g
CAN interface (physical layer)	According to ISO 11898-1 & ISO 11898-2 (CAN 2.0 A/B), Short circuit protected
CANopen application layer and communication profile	CANopen Safety protocol: EN 50325-5, CANopen protocol: EN 50325-4 (CiA 301 v4.0 and 4.2.0) CANopen device profile for inclinometers: CiA 410 version 2.0.0
Baud rate	125 kbit/s (default, range 10/20/50/100/125/250/500/800/1000 kbit/s)
Node Id	01h (default, range: 01h - 7Fh)
TPDO1 event time	50 ms (default, range 10-5000 ms)
Sync mode (TPDO's)	off (default, range on/off)
Heartbeat	off (default, range on/off)
Output format	Integer: -3000 to +3000 (SRDO:X=byte 2,1; Y=byte 4,3) (byte 5,6,7,8: integer 0)
SRDO1 COB-ID1	101h (default, range: FFh + 2x node ID -> 101h-17Fh)
SRDO1 COB-ID2	102h (default, range: 100h + 2x node ID -> 102h-180h)
Safeguard cycle time (SCT)	80ms(default, worst case 100ms)
Safety related validation time (SRVT)	20ms
Filtering	Output filter disabled
Reaction on error	Emergency message 080h+Node-ID followed by NMT stop state (no CAN communication)
Boot time	< 1 s
Programming options	by CANopen object dictionary (CAN parameters, filtering)

QG series

QG65N-KDXYh-030-CANS-C(F)M-UL-2d

CANoutput = $100 \cdot \alpha$
 Clipping outside measuring range

Default 0°: horizontal (label upwards), no acceleration applied. To eliminate mounting offsets the sensor can be centered within $\pm 5^\circ$ tilt (by the CAN object dictionary)

Cross tilt sensitivity error:
 $< (0,12 \cdot \text{cross tilt angle})^2 \%$ typ.

→ one axis $< 10^\circ$ tilt for max. accuracy

Connection

Wire / pin coding

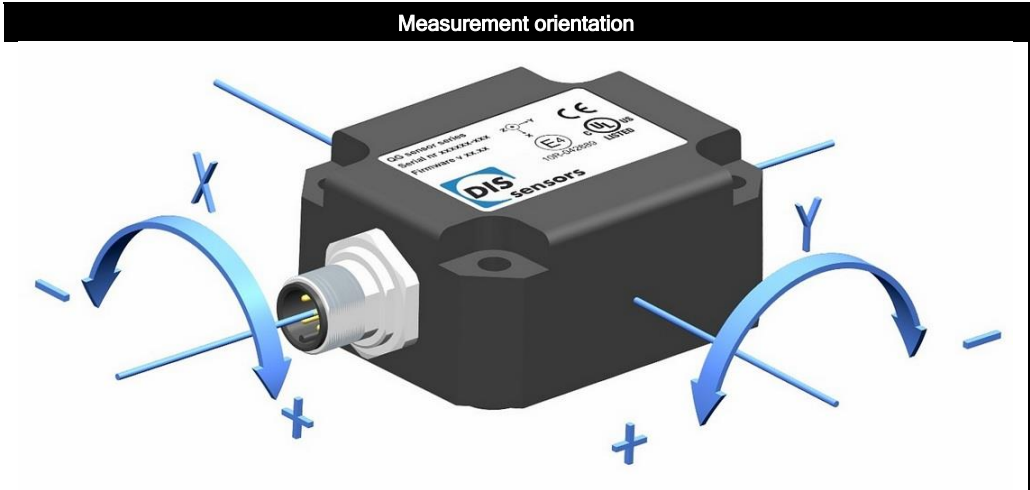
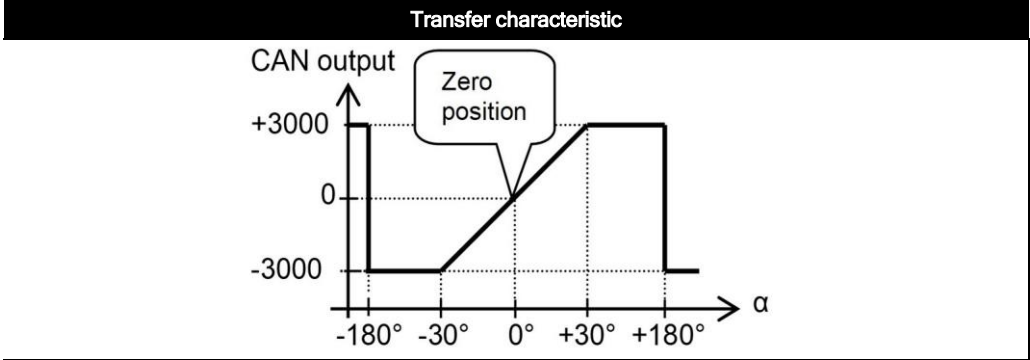

Connectivity (cable length $\pm 10\%$)

Male only or Male & Female (internal T-junction) M12 connector (5 pins, A-coding)
 (CiA303 V1.8.0) (Brass Nickel coated, contacts copper alloy)
 No bus termination inside. A CANbus always has to be terminated properly. For bus termination order separate M12 termination resistor (optional: T-connector)

Pin 1:	Shield		
Pin 2:	Vcc		
Pin 3:	Gnd & CAN_GND		
Pin 4:	CAN_H		
Pin 5:	CAN_L		

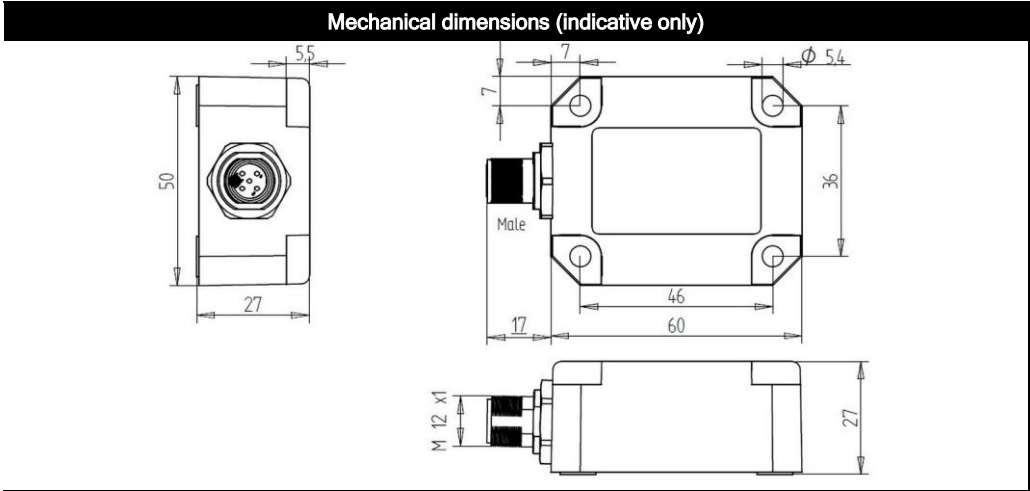

UL, CAN-manual, EDS-file, Safety information, Ordering codes

QG series sensors are intended to measure inclination, acceleration or tilt angle after installing in machines, equipment and systems. Flawless function in accordance with the specifications is ensured only when the device is used within its specifications. Modifications or non-approved use are not permitted and will result in loss of warranty and void any claims against the manufacturer.

UL & c-UL listed product (File number E312057, UL508 standards UL60947-5-2 & CSA-C22.2 No. 14)
 Product Identity / Category Code Number (CCN): Industrial Control Equipment / NRKH & NRKH7
 Enclosure rating: type 1, Ambient temperature: max 80 °C (see also datasheet, lowest value applies)
 Electrical ratings: Intended to be used with a Class 2 power source in accordance with UL1310, max. input Voltage 32V dc (see also datasheet, lowest value applies), max. current 200mA
 Accessory Cable Assembly: Any UL-listed (CYJV/7) mating connector with mechanical locking, wire thickness of at least 30 AWG (0,05 mm²), recommended ≤23 AWG (≥0,25 mm²)

A CANOpen-safety manual (Dtype), EDS-files (CiA306 V1.3.0) and a Declaration of Conformity are available on www.dis-sensors.com/downloads

Safety information:

- this datasheet + relevant manual must be read and understood before using this safety device
- certified level: SIL CL 2 (acc. to IEC 62061), PLd (acc. to EN ISO 13849)
- EC type examination by DEKRA testing and Certification GmbH Certificate no. 4821024.21001
- Hardware architecture: HFT=1 (according IEC 62061, CAT.3 (according to EN ISO 13849)
- Standard (-40°C to +45°C): MTTFd: 447 year, DC: 93%, CCF: 70 pt, SFF: 98%, PFHd: 14E-09
- High Temp. (up to +85 °C): MTTFd: 73 year, DC: 93%, CCF: 70 pt, SFF: 98%, PFHd: 91E-09
- only a SELV power supply should be used
- Redundancy Compare Time (error if this time is expired): customer adjustable (default 2000ms)
- Redundancy Compare Angle (error if angle-difference > this value): customer adjustable (default 3°)
- Redundancy error: Redundancy Compare Angle & Redundancy Compare Time exceeded
- Error: any detected error or a redundancy error
- Safety Related Fault Respons Time (SRFRT): 100ms + Redundancy Compare Time (default 2000ms)

Optional: for accurate mounting two factory mounted positioning pins can be mounted (Ø4mm) replacing 2x M5x25 mm.

As this device is accelerometer-based the sensor is inherent sensitive for accelerations/vibrations. Application specific testing must be carried out to check whether this sensor will fulfil your requirements.

Ordering codes:

M12 Male: QG65N-KDXYh-030-CANS-CM-UL-2d, 12080

M12 Male & Female: QG65N-KDXYh-030-CANS-CFM-UL-2d, 12083