

## QG65N2 SAE J1939 High accuracy series

QG65N2-KDXyh-090H-CANJ-C(F)M-UL

### Inclination sensor

2 axis horizontal mounting

Programmable device

Interface: CAN SAE J1939

Parameters programmable  
by J1939

Measuring range  
 $\pm 90^\circ$

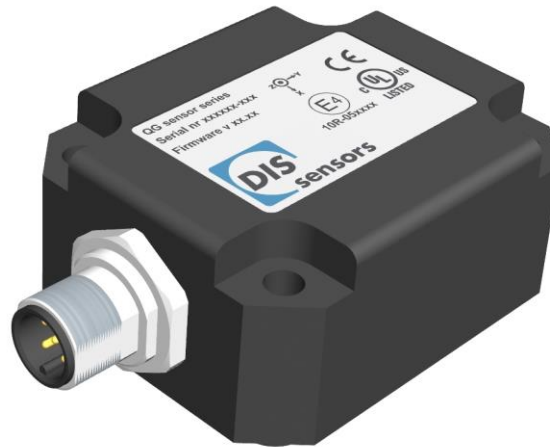

SAE J1939



### General specifications v20211130

Housing	Reinforced plastic injection molded (Faradex DS, black, EMI shielded by stainless steel fiber in PC)
Dimensions (indicative)	60x50x27 mm
Mounting	Included: 4x M5x25 mm zinc plated steel pozidrive pan head screws, self-tapping (PZ DIN7500CZ) (optional: Factory mounted 2x Ø4mm positioning pins replacing 2x M5x25 mm)
Ingress Protection (IEC 60529)	IP67, IP69K (with IP69K mating connector)
Relative humidity	0 - 95% (non condensing, housing fully potted)
Weight	approx. 110 gram
Supply voltage	10 - 32 V dc
Polarity protection	Yes
Current consumption	50mA typ. For CFM models (daisy-chained CANbus): max. current internal T-junction: 2.5A
Operating temperature	-40 .. +80 °C
Storage temperature	-40 .. +85 °C
Measuring range	$\pm 90^\circ$
Centering function	Yes (CANout 0 = 0°), range: $\pm 5^\circ$
Frequency response (-3dB)	0 - 10 Hz
Accuracy (overall @20°C)	0,07° typ.
Offset error	$\pm 0,01^\circ$ typ. ( $\pm 0,02^\circ$ 2 $\sigma$ ) after centering
Non linearity	$\pm 0,06^\circ$ typ., $\pm 0,1^\circ$ 2 $\sigma$ , $\pm 0,15^\circ$ max.
Sensitivity error	not applicable. Repeatability 0,05°
Resolution	0,01°
Temperature coefficient	$\pm 0.003^\circ/K$ typ., $\pm 0.005^\circ/K$ (2 $\sigma$ )
Max mechanical shock	10,000g (max 0,2ms)
CAN interface	According to ISO 11898-1 & ISO 11898-2 (CAN 2.0 A/B), Short circuit protected
SAE J1939	SAE J1939
Baud rate	250 kbit/s (range 250/500kbit/s)
Default address	80h = 128dec
PGN	Inclination: FF00h = 65280dec, acceleration: FF03h = 65283dec
PGN cycle time	100ms
Priority	3 (default)
Output format	Integer: -9000 to +9000 (X=byte 1,0; Y=byte 3,2)
Internal CANbus termination	120 Ohm on/off (default: off)
Boot time	< 0.5 s
Programming options	J1939 parameters: baud rate, device address PGN, cycle time, priority. Sensor functions: internal CANbus termination

# QG series

## QG65N2-KDXYh-090H-CANJ-C(F)M-UL

J1939 output =  $100 \cdot \alpha$   
 Clipping outside measuring range

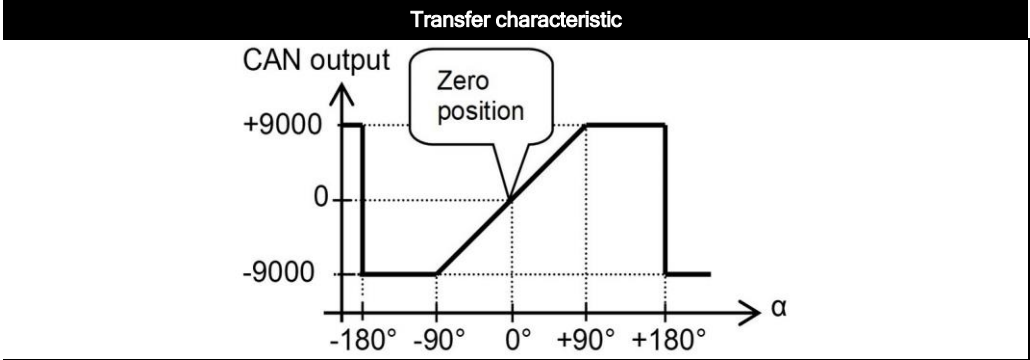

Default 0°: horizontal (label upwards), no acceleration applied. To eliminate mounting offsets the sensor can be zero-ed within  $\pm 5^\circ$  tilt (by the CAN object dictionary)

Cross tilt sensitivity error:  
 $< (0,12 \cdot \text{cross tilt angle})^2 \%$  typ.

→ one axis  $< 10^\circ$  tilt for max. accuracy

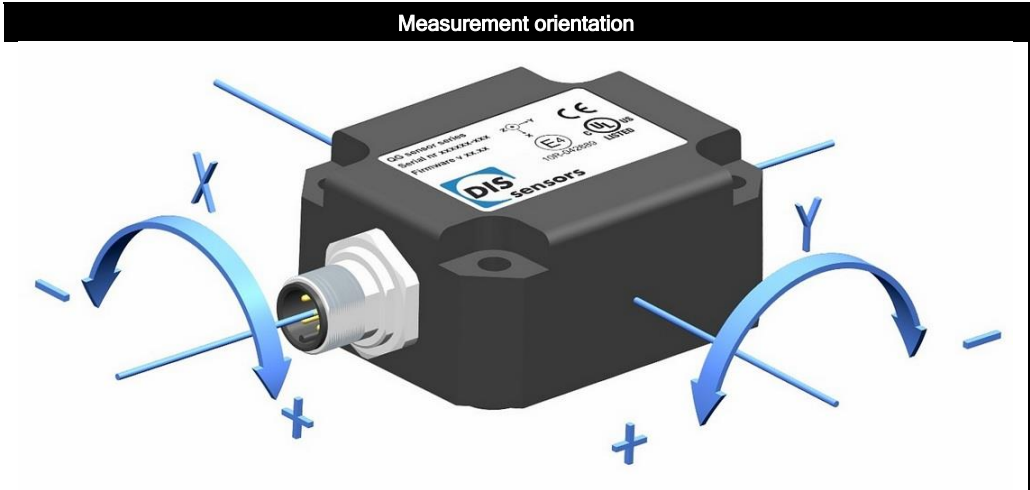

Connection

**Connectivity (cable length  $\pm 10\%$ )**

Male only or Male & Female (internal T-junction) M12 connector (5 pins, A-coding) ( CiA303 V1.8.0 ) (Brass Nickel coated, contacts copper alloy)

A CANbus always has to be terminated properly according to customers bus topology and general CAN rules.  
 The sensor has an on-board internal 120 Ohm CANbus termination resistor that can be switched on by the CANopen dictionary (default: off).  
 Alternatively an external M12 termination resistor can be connected when using a Male & Female (internal T-junction) model.  
 External M12 termination resistors and T-connectors are available as accessoires, see DIS website.

Wire / pin coding



Mechanical dimensions (indicative only)

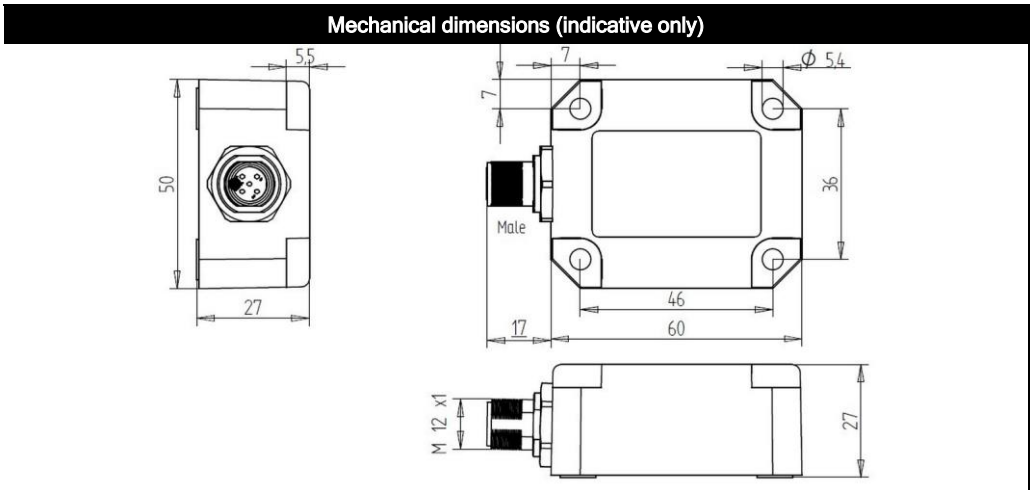

## E4, UL, J1939-manual, Ordering codes

Before using this device, please read this datasheet, the Manual and the Declaration of Conformity carefully (download from [dis-sensors.com](http://dis-sensors.com))

This product is approved for automotive use, approval number: E4-10R-05-4662

Connect this sensor only to an approved CAN controller which must have a grounded shield. Alternatively, connect the sensor housing to a grounded shield. All mentioned EMC standards that are met (see Declaration of Conformity) have been done with the housing connected to a grounded shield.

QG series sensors are intended to measure inclination/acceleration/tilt. Flawless function (acc. spec.) is ensured only when used within specifications. This device is not a safety component acc. to EU Machine Directive (ISO13849). For full redundancy two devices can be used. Modifications or non-approved use will result in loss of warranty and void any claims against the manufacturer.

UL & c-UL listed product (File number E312057, UL508 standards UL60947-5-2 & CSA-C22.2 No. 14)  
Product Identity / Category Code Number (CCN): Industrial Control Equipment / NRKH & NRKH7  
Enclosure rating: type 1, Ambient temperature: max 80 °C (see also datasheet, lowest value applies)  
Electrical ratings: Intended to be used with a Class 2 power source in accordance with UL1310, max. input Voltage 32V dc (see also datasheet, lowest value applies), max. current 200mA  
Accessory Cable Assembly: Any UL-listed (CYJV/7) mating connector with mechanical locking, wire thickness of at least 30 AWG (0,05 mm<sup>2</sup>), recommended ≤23 AWG (≥0,25 mm<sup>2</sup>)

As this device is accelerometer-based the sensor is inherent sensitive for accelerations/vibrations. Application specific testing must be carried out to check whether this sensor will fulfil customers requirements.

A 1939 manual can be downloaded from the website (Type JB)

Ordering codes:

QG65N2-KDXYh-090H-CANJ-CM-UL: t.b.d.

QG65N2-KDXYh-090H-CANJ-CFM-UL: t.b.d.